

Yamataha ThermJet Burners

Model TJ1500

Data sheet Edition 03.18

Version 2

Parameter	Burner Velocity		Model TJ1500
Maximum Input, Btu/h (kW)¹	Medium & High Velocity		15,000,000 (3956)
Minimum Input, Btu/h (kW)¹ <i>For lower inputs, contact Yamataha, Inc.</i>	Medium & High Velocity		1,500,000 (396)
Minimum Input Fixed Air, Btu/h (kW)¹	Medium & High Velocity		300,000 (79)
Main Gas Inlet Pressure, "w.c. (mbar) <i>Fuel pressure at gas inlet Tap B (see page 3)</i>	High Velocity	Natural Gas	15.7 (39.1)
		Propane	15.7 (39.1)
		Butane	15.7 (39.1)
	Medium Velocity	Natural Gas	3.7 (9.2)
		Propane	3.7 (9.2)
		Butane	3.7 (9.2)
Air Inlet Pressure, "w.c. (mbar) <i>15% excess air at maximum input Tap A (see page 3)</i>	High Velocity	Natural Gas	19.7 (49.1)
		Propane	19.7 (49.1)
		Butane	19.7 (49.1)
	Medium Velocity	Natural Gas	8.4 (20.9)
		Propane	8.4 (20.9)
		Butane	8.4 (20.9)
High Fire Visible Flame Length, inches (mm) <i>Measured from the outlet end of the combustor</i>	High Velocity	Natural Gas	84 (2134)
		Propane	108 (2743)
		Butane	108 (2743)
	Medium Velocity	Natural Gas	144 (3660)
		Propane	185 (4700)
		Butane	185 (4700)
Approximate Flame Velocity, ft/s (m/s) <i>Approximately 15% excess air at maximum input</i>	High Velocity		560 (171)
	Medium Velocity		180 (55)
Maximum Combustion Air Temperature	300°F (149°C). For higher temperatures use TJPCA (Datasheet 206).		
Flame Detection	UV scanners can be used with all combustors.		
Fuels² <i>For any other mixed gas, contact Yamataha, Inc.</i>	Natural gas, Propane or Butane		
Approvals			

- All imperial inputs based upon gross calorific values (HHV). All metric inputs based upon net calorific values (LHV).
 - See Design Guide 205 for more information about typical fuel composition and properties.
- All information is based on laboratory testing in neutral (0 "w.c., 0 mbar) pressure chamber. Different chamber conditions may affect the data.
 - All information is based on standard combustor design. Changes in combustor will alter performance and pressures.
 - All inputs based upon standard conditions; 1 atmosphere, 70°F (21°C).
 - Yamataha reserves the right to change the construction and/or configuration of our products at any time without being obliged to adjust earlier supplies accordingly.
 - Plumbing of air and gas will affect accuracy of orifice readings. All information is based on generally acceptable air and gas piping practices.

Yamataha

Performance Graphs

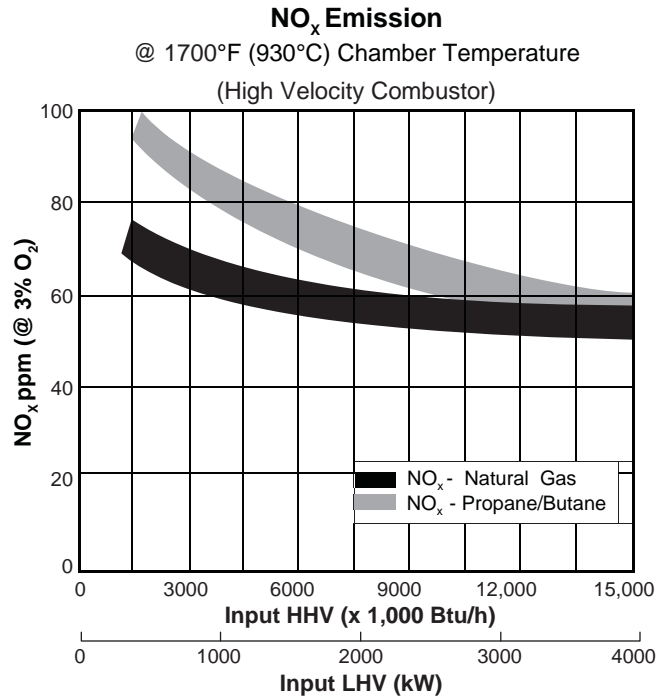
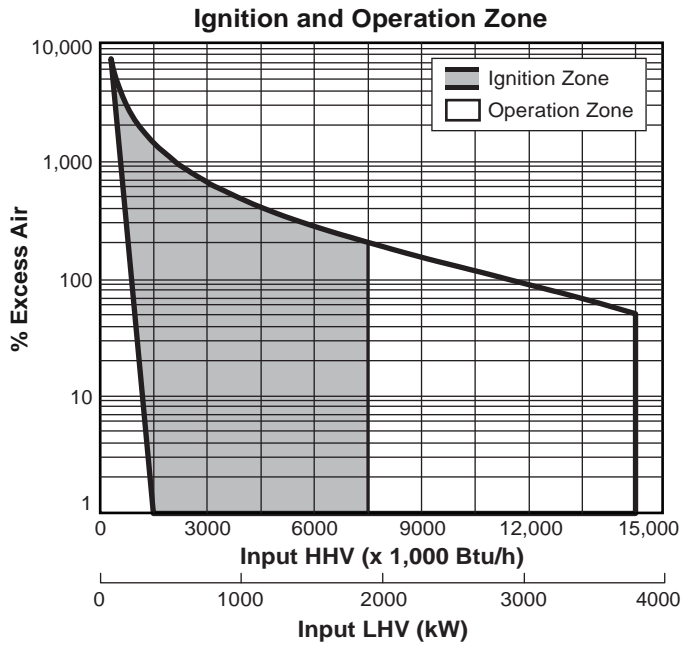

Emissions correction factor for medium velocity combustor is 1.20. Emissions data based on, on-ratio control firing at 15% excess air corrected to 3% O₂.

Emissions from the burner are influenced by:

- Fuel type
- Combustion air temperature
- Firing rate
- Chamber conditions
- Percent of excess air

For estimates of other emissions, contact Yamataha.

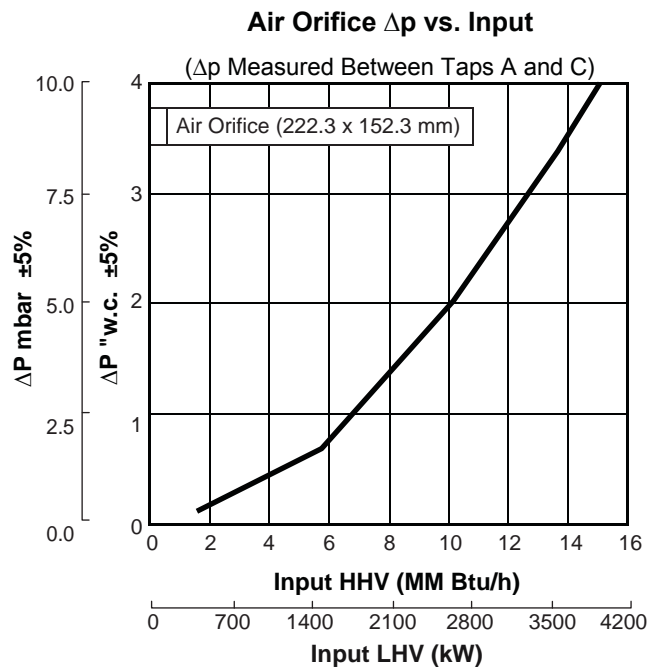
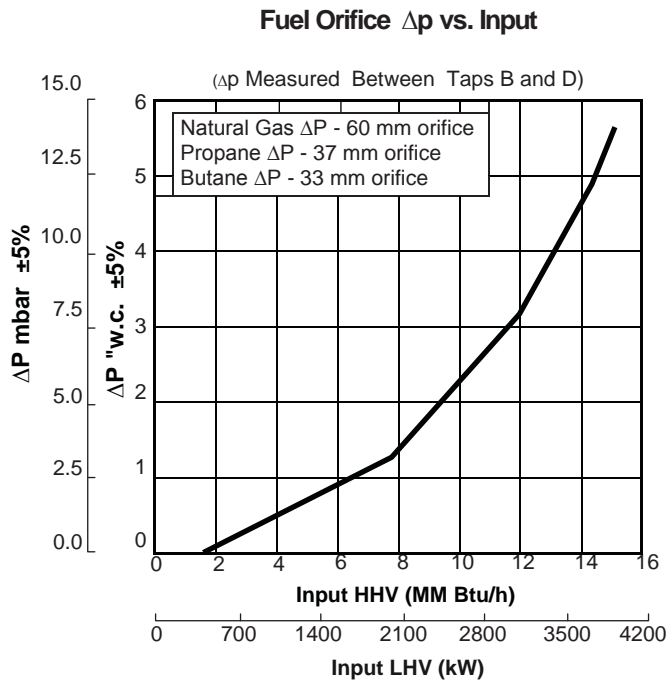

Dimensions and Specifications

Dimensions in mm (inches)

Burner Housing

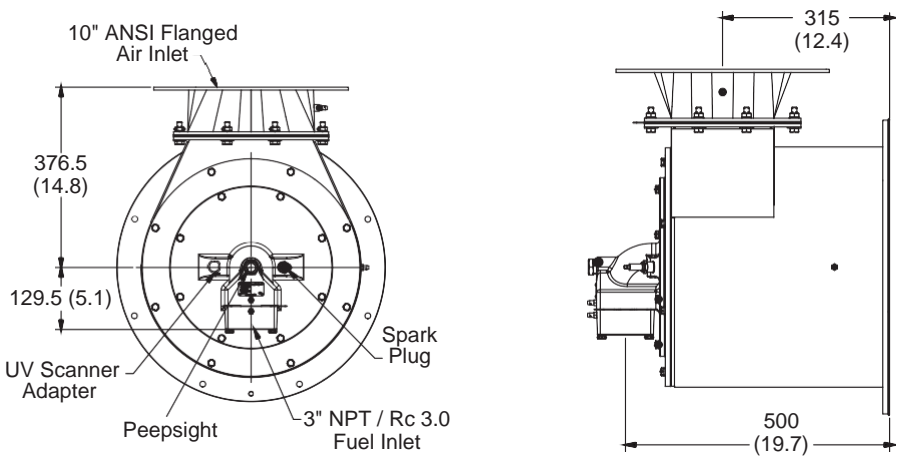

Burner weight less combustor: 208 lbs (95 kg)

Tap Locations

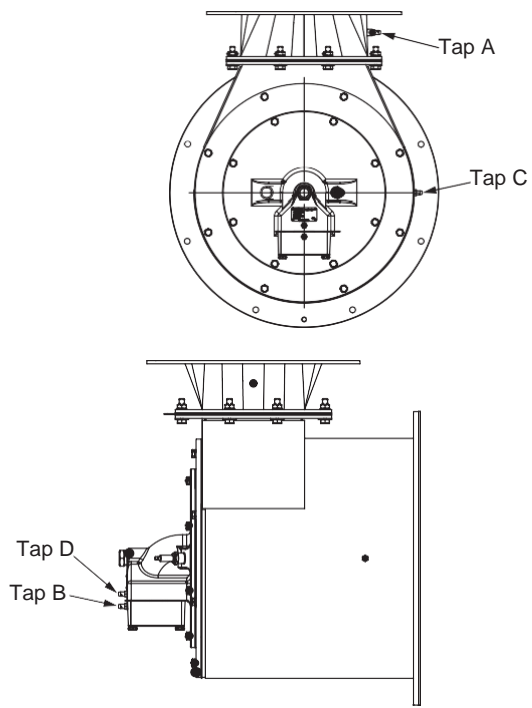

Dimensions and Specifications

Dimensions in mm (inches)

Combustors

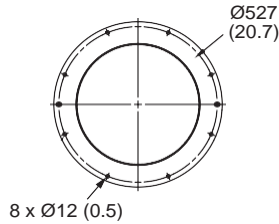
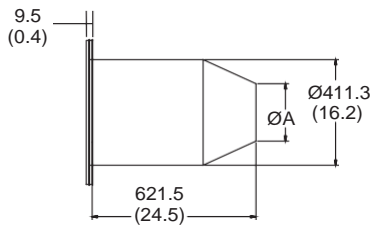

Alloy Combustor (AISI 310)
 Weight: 44 lbs (20 kg)
 Maximum Chamber Temp: 1,750°F (950°C)

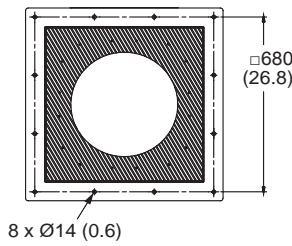
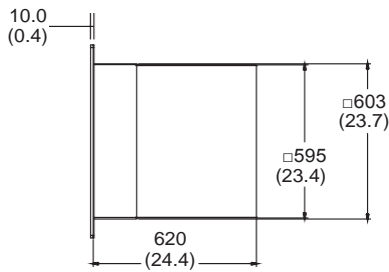

Refractory Combustor with AISI 330 wrapper
 Weight: 1000 lbs (454 kg)
 Maximum Chamber Temp: 2,800°F (1,538°C)

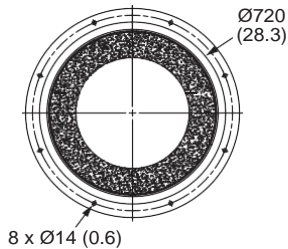
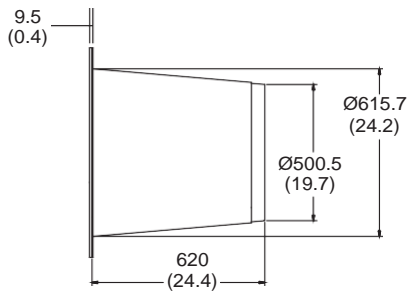

Down Firing Block with AISI 330 wrapper
 Weight: 610 lbs (277 kg)
 Maximum Chamber Temp: 2,800°F (1,538°C)

NOTE: Mounting gasket shown on right side of combustor flange.
 Dimensions shown do not account for mounting gasket.

Dimension	High Velocity	Medium Velocity
ØA	Ø223 (8.8) (tapered)	Ø409 (16.1) (straight)