



บริษัท เอดีดี เฟอร์เนส จำกัด

ADD FURNACE CO.,LTD.

44 ซอยบรมราชชนนี 70 ถนนบรมราชชนนี แขวงศาลาธรรมสพน์ เขตทวีวัฒนา กรุงเทพฯ 10170

โทร: 02-888-3472 โทร: ออกแบบ:08-08-170-170 แฟกซ์: 02-888-3258

https://www.add-furnace.com E-mail: sales@add-furnace.com

Shimaden, Temperature and Humidity Control Specialists

°C	SERIES PAC15
%RH	
SHIMADEN	

SINGLE PHASE POWER REGULATOR

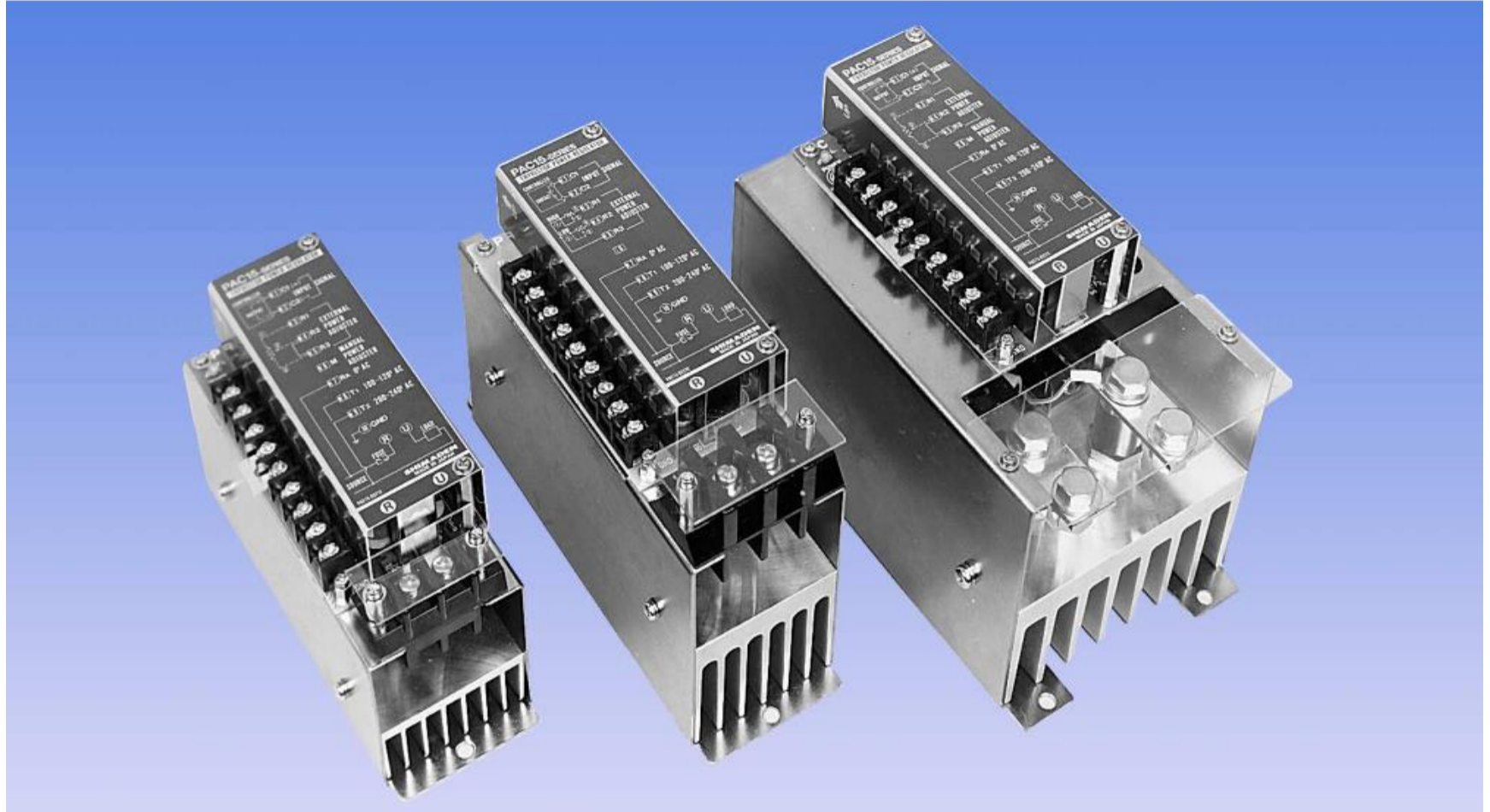

BASIC FEATURES

- Phase Angle or Zero Voltage Switching**
- Current Capacity: 20~100 Amperes**
- Power Supply: 100~120 / 200~240V AC**

SPECIFICATIONS

Control Mode:	Phase angle (PAC15P) Zero voltage switching (PAC15C)
Possible Loads:	All resistance loads (PAC15P) Constant resistance loads (PAC15C)
Power Supply Cycle:	50/60Hz. (internally selectable-PAC15P) 50/60Hz. common (PAC15C)
Output Voltage Control Range:	0~95% min. 50/60Hz. of input voltage (PAC15P) 0~95% min. of load power (PAC15C)
Power Lamp:	Green LED lamp (PAC15P)
Output Indication:	Green LED lamp (when load 'ON'-PAC15C)
Current Capacity:	20, 30, 45, 60, 80 and 100 Amps.
Power Supply:	100~120V/200~240V AC \pm 10%
Control Input:	Current = 4~20mA DC (Receiving impedance: 100 ohms) Contact = Zero voltage contact
Power Adjuster:	Current input = Internal installation as standard (External installation as option) Contact input = External installation as standard
Auto/Manual Power Adjuster:	Only current input type is available - optional
Thyristor Element Cooling:	Natural air
Over-Current Protection:	None available (Use a fuse for semiconductor)
Minimum Load:	10% min. of current capacity (no operation at no load)
Operating Ambient Temperature and Humidity:	-10~50°C, 90%RH maximum
Insulation Resistance:	500V DC 20M ohms between power supply terminals and chassis 500V DC 20M ohms between power supply terminals and input terminals
Dielectric Strength:	1 min. at 2000V AC between power supply terminals and chassis
Dimensions and Weight:	See page 4.



บริษัท เอดีดี เฟอร์เนส จำกัด

ADD FURNACE CO.,LTD.

44 ซอยบรมราชชนนี 70 ถนนบรมราชชนนี แขวงศาลาธรรมสพน์ เขตทวีวัฒนา กรุงเทพฯ 10170

โทร: 02-888-3472 โทร: ออกแบบ:08-08-170-170 แฟกซ์: 02-888-3258

https://www.add-furnace.com E-mail: sales@add-furnace.com

ORDERING INFORMATION

Series PAC15

ITEMS	CODE	SPECIFICATIONS	
SERIES	PAC15P	Phase Angle Single Phase Power Regulator	
	PAC15C	Cycle Base Zero Voltage Switching Single Phase Power Regulator	
CONTROL INPUT	0	4~20mA DC, Receiving impedance: 100Ω	
	2	Non-voltage contact	
	9	Others (Please consult before ordering.)	
CURRENT CAPACITY	020	20A	
	030	30A	
	045	45A	
	060	60A	
	080	80A	
	100	100A	
POWER SUPPLY	81-	100~120V / 200~240V AC ±10%, 50 / 60Hz	
	99-	Others (Please consult before ordering.)	
EXTERNAL POWER ADJUSTER	N	None (Internal installation as standard)	Current input
	P	External power adjuster	
	M	Manual power adjuster	
	B	Base power adjuster	
	W	External power adjuster + manual power adjuster	
	Y	External power adjuster + base power adjuster	
	P	High power adjuster (standard)	Contact input
	B	High power adjuster (standard) + Low power adjuster	
	X	Others (Please consult before ordering.)	
REMARKS	0	Without	
	9	With (Please consult before ordering.)	

TERMINALS & WIRING (CURRENT INPUT TYPE)

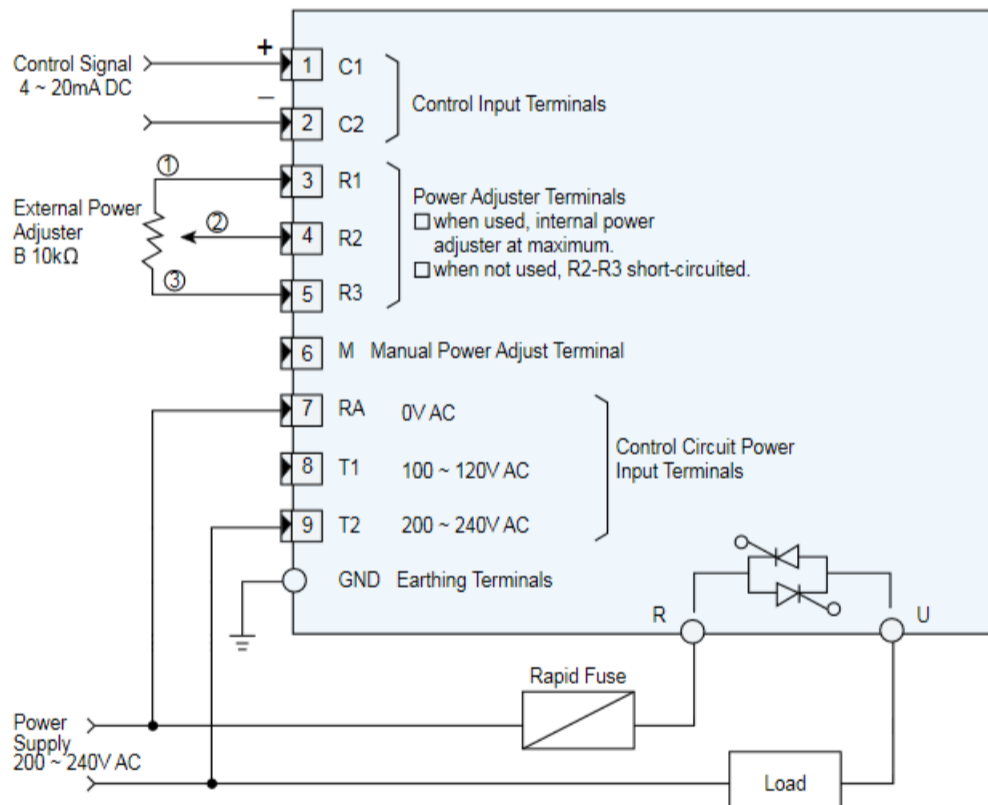

POWER ADJUSTER CONNECTIONS (CURRENT INPUT TYPE)

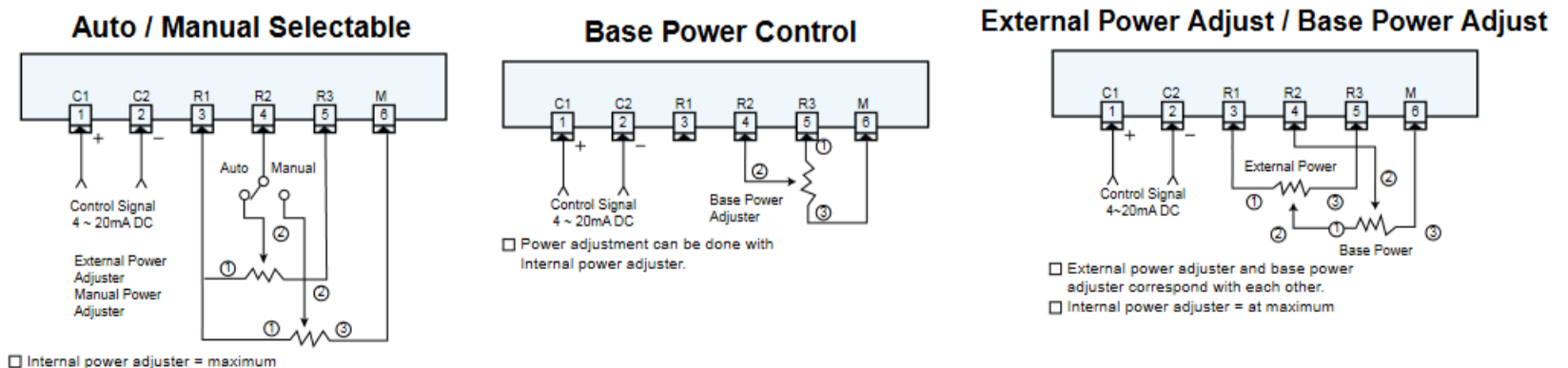



TERMINALS & WIRING (CONTACT INPUT TYPE)

Series PAC15

1. Normal Control

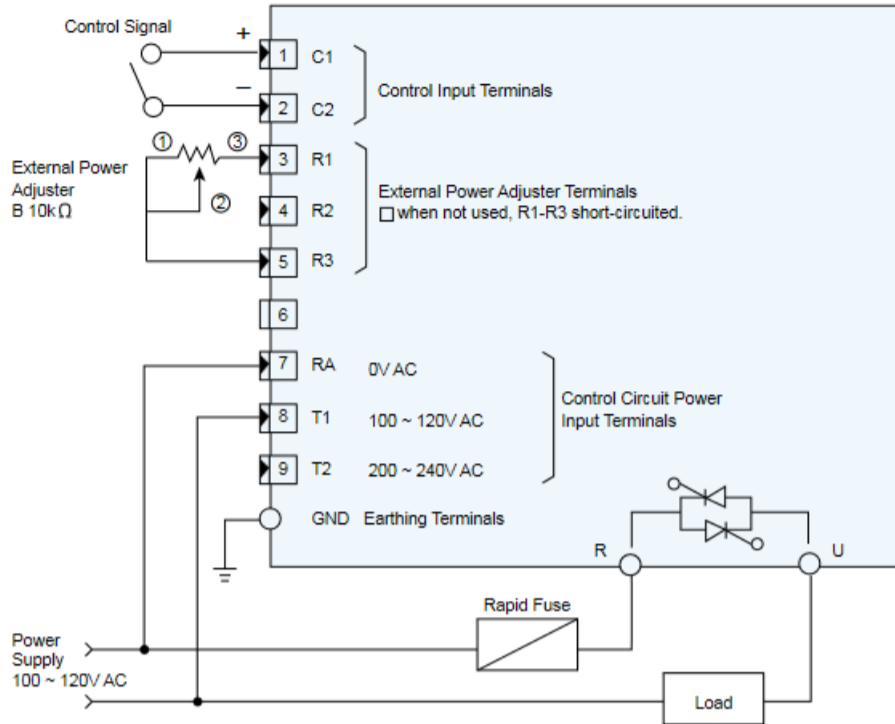

2. High/Low Control

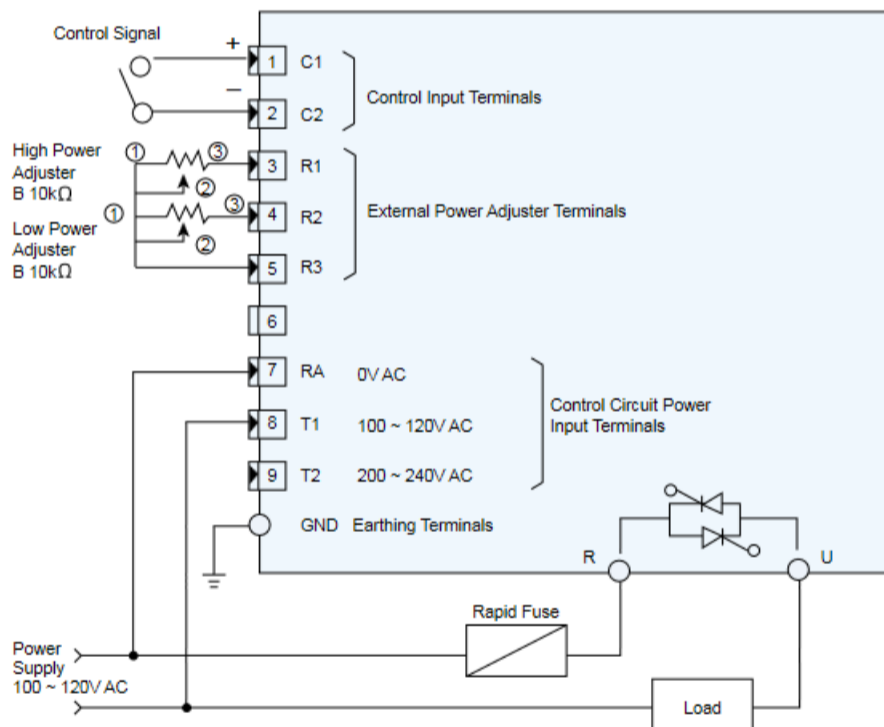

- Output when high power adjust/contact (C1-C2=ON)
0~100% power output control available by high power adjuster.
- Output when low power adjust/contact=OPEN
- Low Power Output=
High Power Value+Low Power Value-100%
(When output of low power is (-), low power output is zero.)

CONTROL MODES & WAVE FORM

Control Mode	Noise	Moving Coil Deflection	Heating Element Capacity	Output Wave Form		
				10% Output	50% Output	90% Output
Phase Angle Control (P)	Little	Continuous	Very Small			
Zero-voltage Switching Control (C)	None	Low Output/ Large Deflection Mid ~ High Output/Almost Continuous	Small	 1 cycle ON and 9 cycle OFF	 1 cycle ON and 1 cycle OFF continuously	 9 cycle ON and 1 cycle OFF

PAC15 Series Total Heating Value

Capacity	20 A	30 A	45 A	60 A	80 A	100 A
Heating Value	24 W	36 W	48 W	60 W	84W	100 W

Recommended mounting

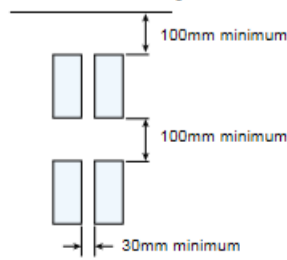

*Care must be taken for air-ventilation.

*Vertical mounting is recommended.

When mounting horizontally, use at 70% of the current capacity.



บริษัท เอดีดี เฟอร์เนส จำกัด

ADD FURNACE CO.,LTD.

44 ซอยบรมราชชนนี 70 ถนนบรมราชชนนี แขวงศาลาธรรมสพน์ เขตทวีวัฒนา กรุงเทพฯ 10170

โทร: 02-888-3472 โทร: ออกแบบ:08-08-170-170 แฟกซ์: 02-888-3258

https://www.add-furnace.com E-mail: sales@add-furnace.com

EXTERNAL DIMENSIONS & WEIGHT

Series PAC15

□ 20A & 30A Types

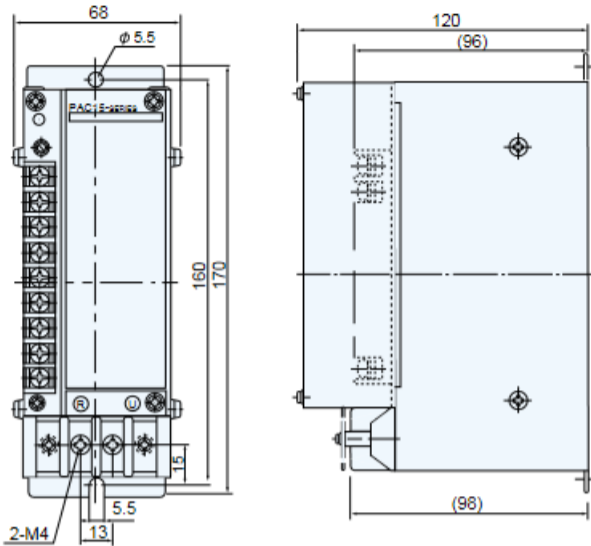

Weight: Approx. 1.2 kg

□ 45A & 60A Types

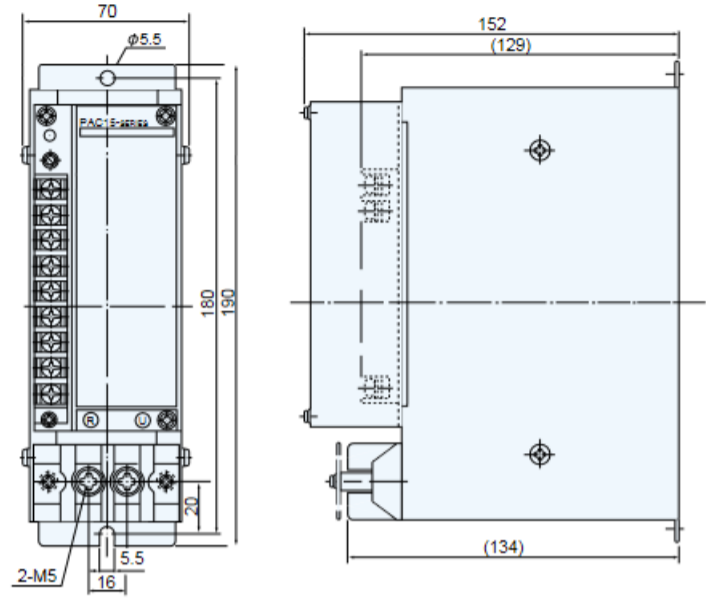

Weight: Approx. 2.0 kg

□ 80A & 100A Types

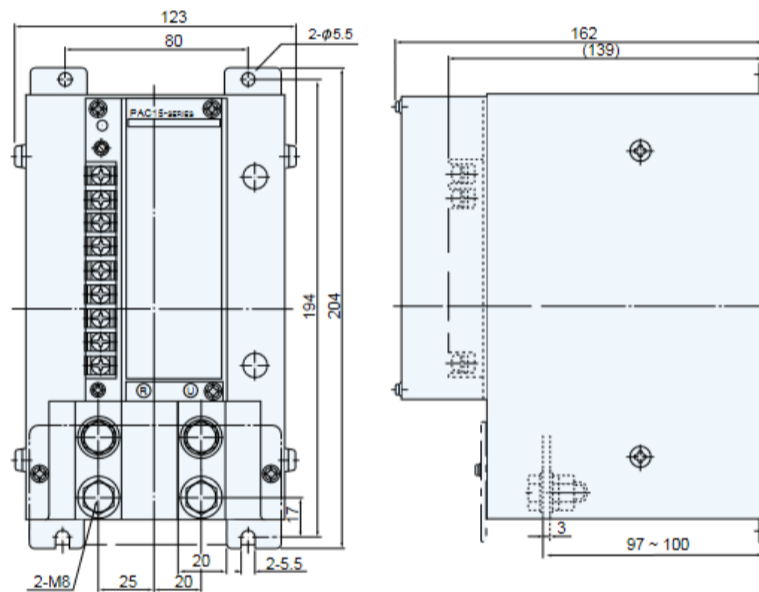

Weight: Approx. 3.4 kg

Unit: mm

⚠ Warning

- The PAC15 series is designed for controlling the power of a heater or similar equipment used in a general industrial facilities. (It is not to be used for any purpose which regulates the prevention of serious effects on human life or safety.)

⚠ Caution

- If the possibility of loss or damage to your system or property as a result of failure of any part of the process exists, proper safety measures must be made before the instrument is put into use so as to prevent the occurrence of trouble.