



บริษัท เอดีดี เฟอร์เนส จำกัด

ADD FURNACE CO.,LTD.

44 ซอยบรมราชชนนี 70 ถนนบรมราชชนนี แขวงศาลาธรรมสพน์ เขตทวีวัฒนา กรุงเทพฯ 10170

โทร: 02-888-3472 โทร: ออกแบบ:08-08-170-170 แฟกซ์: 02-888-3258

<https://www.add-furnace.com> E-mail: sales@add-furnace.com

Bulletin 71.2
D102683X012

299H Series

September 2020

299H Series Pressure Reducing Regulators

- Inlet Pressure up to 175 psig / 12.1 bar
- Compact
- Integral Pilot
- $\pm 1\%$ Accuracy for Fixed Factor Billing (PFM)
- Rugged Construction
- Easy to Maintain

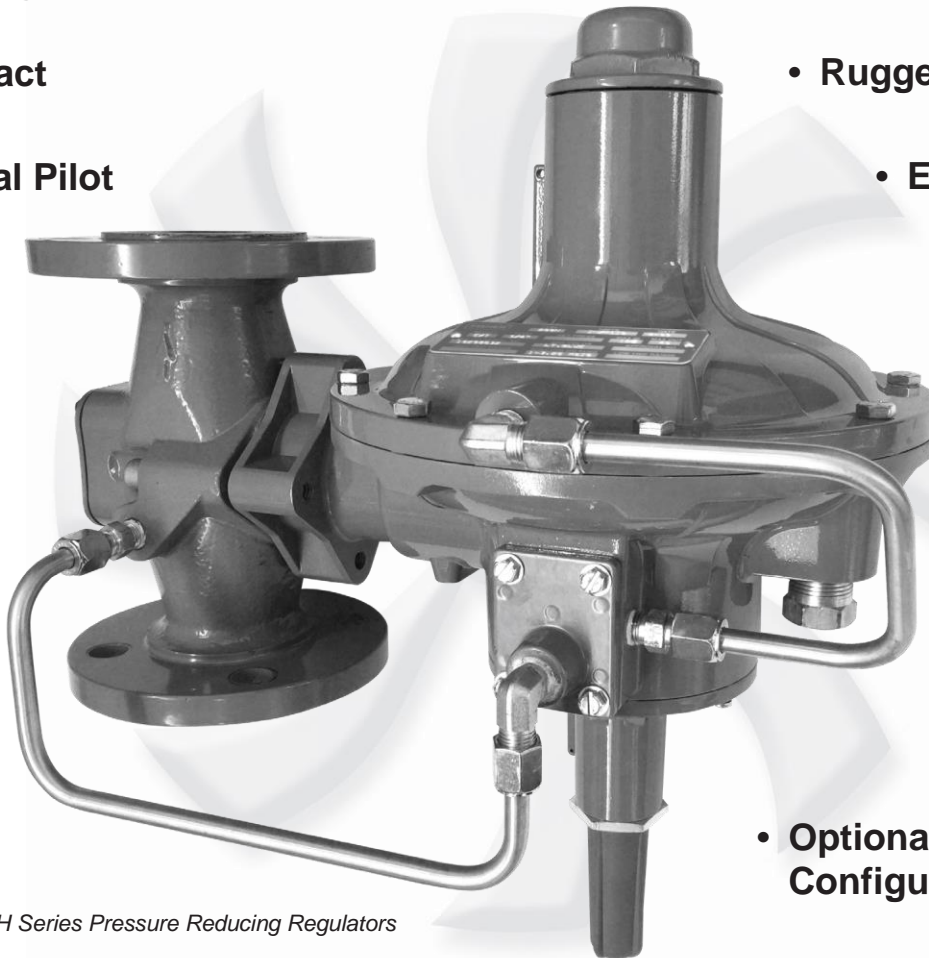

Figure 1. 299H Series Pressure Reducing Regulators

- High Capacity
- Robust
- Outlet Pressures up to 60 psig / 4.1 bar
- Optional Slam-Shut Configuration
- No Bleed Monitor
- External, Internal or Dual Registration
- Optional Token Relief

FISHER™

EMERSON™



299H Series

Specifications

Specifications for 299H Series constructions are given below. Some specifications for a given regulator as it originally comes from the factory are stamped on a nameplate located on the actuator upper casing.

Available Constructions

Type 299H: Pilot-operated pressure reducing regulator with a pilot integrally mounted to the actuator casing.

Type 299HR: A Type 299H with a token internal relief valve to relieve minor overpressure caused by thermal expansion.

Type 299HV: Same as the Type 299H with a Type VSX8 slam-shut valve which provides overpressure or overpressure and underpressure protection.

Type 299HVR: Same as the Type 299HV with an internal token relief valve.

Body Size and End Connection Styles

See Table 1

Maximum Operating Inlet Pressure by Orifice Size⁽¹⁾

1/4 x 3/8 in. / 6.4 x 9.5 mm175 psig / 12.1 bar
3/8 in. / 9.5 mm175 psig / 12.1 bar
1/2 in. / 13 mm175 psig / 12.1 bar
3/4 in. / 19 mm150 psig / 10.3 bar
7/8 in. / 22 mm ⁽⁵⁾125 psig / 8.6 bar
1 in. / 25 mm ⁽⁵⁾100 psig / 6.9 bar
1-3/16 in. / 30 mm ⁽⁵⁾	80 psig / 5.5 bar

Maximum Casing and Emergency Outlet Pressure⁽¹⁾

66 psig / 4.5 bar

Outlet (Control) Pressure Ranges⁽¹⁾⁽²⁾

See Table 2

Maximum Set Pressure for Type 299HV⁽¹⁾

16 psig / 1.1 bar

Maximum Set Pressure for Slam-Shut Device⁽¹⁾

See Table 2

Minimum and Maximum Slam-Shut Trip Pressure Ranges

Types 299HV and 299HVR: 21 psig / 1.45 bar

Type VSX8 Sensing Line Connection

1/4 NPT

Flow Coefficients

See Table 3

Flow Capacities

See Tables 5 through 10

Pressure Control Accuracy (Fixed Factor) (PFM)

±1%⁽³⁾ of absolute control pressure

Minimum Differential Pressure For Full Stroke

1.5 psid / 0.10 bar d

Control Line Connections

3/4 NPT; See Figures 8 and 9

Temperature Capabilities⁽¹⁾⁽⁶⁾

-20 to 150°F / -29 to 66°C

Approximate Weight

21 lbs / 10 kg

Pressure Registration

Internal, External or Dual Registration
See Figure 3

Fixed Restriction Sizes

0.044 in. / 1.1 mm, Red (standard gain)
0.071 in. / 1.8 mm, Green (low gain)
0.082 in. / 2.1 mm, Blue (lower gain)

Options

- **Filter⁽³⁾:** A P590 Series filter installed in the pilot supply tubing between main body and pilot
- **Filtered pilot supply regulator⁽³⁾⁽⁴⁾:** A Type 67CF supply regulator with integral 5 micron Polyethylene filter
- **Reed switch:** An optional remote notification switch can be installed offering the capability to remotely notify the operator should VSX8 Series shut off occur. (Types 299HV and 299HVR only)

Construction Materials

- Actuator Upper Casings:** Aluminum
- Actuator Lower Casing:** Aluminum
- Pilot Spring Case:** Aluminum
- Actuator Diaphragm:** Nitrile (NBR)
- Pilot Diaphragm:** Nitrile (NBR)
- Pilot Inlet Screen:** Stainless steel
- Valve Body:** Cast iron, Ductile iron or Steel
- Orifice and Valve Stem:** Aluminum
- Disk Holder:** Aluminum holder with Nitrile (NBR) disk
- Main Disk Construction:** Nitrile (NBR)
- Metal Trim Parts For Pilot:** Aluminum
- Pilot Disk Construction:** Nitrile (NBR)
- O-rings:** Nitrile (NBR)
- Fittings:** Steel (standard) or Stainless steel
- Tubing:** Stainless steel

1. The pressure/temperature limits in this Bulletin and any applicable standard or code limitation should not be exceeded.
 2. For optimum performance, a pilot supply regulator may be installed in the pilot supply tubing between the main valve and pilot.
 3. A pilot supply regulator or a P590 Series filter (only one may be used, not both) may be ordered with the Type 299H, but not both.
 4. For in. w.c., use a pilot supply regulator if actual inlet pressure varies more than ±20 psi / ±1.4 bar and published accuracy is required.
 5. This orifice size is not available for Types 299HV and 299HVR.
 6. Product has passed Emerson Process Management Regulator Technologies, Inc. testing for lockup, relief start-to-discharge and reseal down to -40°.



299H Series

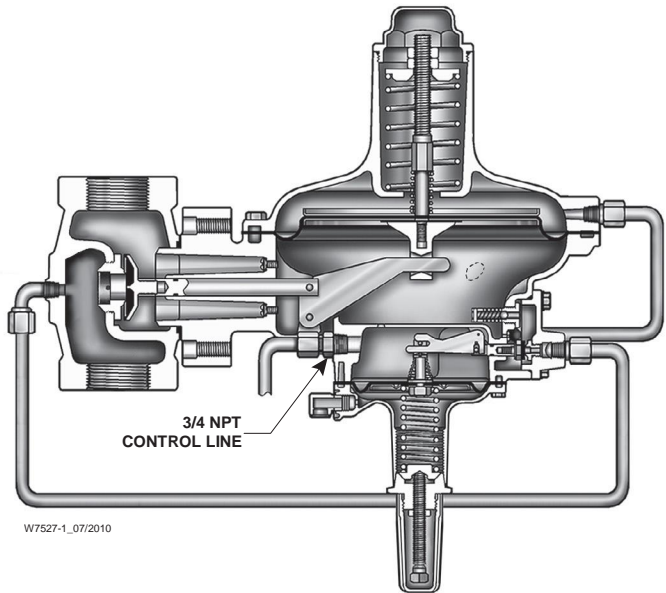

TYPE 299H WITH EXTERNAL REGISTRATION

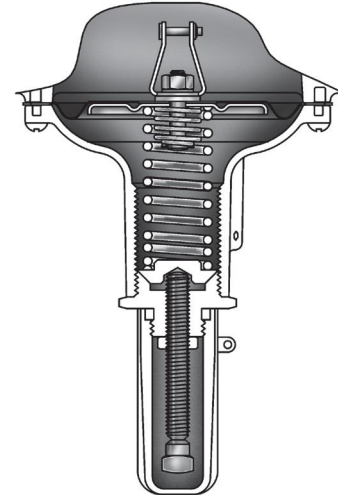

TYPE 299HR PILOT WITH OPTIONAL TOKEN RELIEF

Figure 2. 299H Series Sectional Views

Features

- **Compact in Size**—Small envelope because of the built-in pilot and internal registration.
- **Unique No Bleed Monitor System**—Flexible worker/monitor system setup that allows for bleed to be piped to the intermediate piping thus eliminating downstream bleed which reduces lost and unaccounted for gas. Another advantage of this configuration is that the system lockup pressure is that of the worker instead of the monitor.
- **Not an Adaptation of Existing Regulators**—New design of integrated cases and internal registration ports.
- **Wide Variety of Applications**—Natural gas distribution systems, gas supply to industrial boilers, furnaces, ovens, mixers, plant air service.
- **Highest Quality**—Designed and manufactured to ISO 9001 standards.
- **Accuracy**—Keeps constant inlet pressures to downstream equipment by accurately controlling distribution system pressures at widely varying flow rates and supply pressures for maximum efficiency and best operation or by eliminating the need for pressure-compensating meters by holding a steady pressure to the meter inlet.
- **Optional Token Relief**—The Types 299HR and 299HVR with an integral token relief in the pilot is designed to relieve minor overpressure caused by thermal expansion.
- **High-Capacity Pressure Control**—Actuator diaphragm responds quickly to downstream pressure change, causing immediate correction in main valve position. Pilot responds simultaneously and controls final positioning of main valve. This action permits full main valve travel, resulting in higher capacity than could be obtained without an external pilot regulator.
- **Easy Registration Conversion**—Two screws and O-rings change internal registration to external or dual registration.
- **Easy Startup**—No special procedure required.
- **Easy to Maintain**—Main valve disk and orifice can be inspected without removing body from pipeline. Easy access two bolt flange permits quick removal of actuator and pilot from body.
- **Economical, Labor-Saving Installation**—Supply pressure to pilot is factory-piped directly from inlet side of main regulator body, thus requiring no upstream pilot supply line on standard installations.
- **Rugged Construction**—With a two bolt connection of the regulator to the body and no union ring, the 299H Series regulators are designed for longer service life with minimal maintenance requirements.
- **No gaskets**—Reusable O-rings at all serviceable joints.



299H Series

Table 1. Body Sizes and End Connection Styles

BODY SIZE, NPS / DN	BODY MATERIAL AND END CONNECTION STYLES		
	Cast iron (For Types 299H and 299HR only)	Ductile iron	Steel (For Types 299H and 299HR only)
1-1/4 1-1/2	NPT NPT	---- NPT	---- NPT
2 / 50	NPT, CL125 FF Flanged ⁽¹⁾	NPT, CL125 FF and CL250 RF Flanged, PN 10/16 Flanged	NPT, CL150 RF Flanged

1. This flange is available with a face-to-face dimension of 7.5 or 10 in. / 191 or 254 mm.

Table 2. Outlet Pressure Ranges

OUTLET (CONTROL) PRESSURE RANGE		TYPE		PILOT CONTROL SPRING					
		299H	299HR, 299HV and 299HVR	Part Number	Color	Free Length		Wire Diameter	
In. w.c.	mbar					In.	mm	In.	mm
3.5 to 6 ⁽¹⁾	9 to 15 ⁽¹⁾	X	X	T13707T0012	Black	1.86	47.2	0.055	1.40
5 to 9 ⁽¹⁾	12 to 22 ⁽¹⁾	X	X	T13589T0012	Yellow	2.05	52.1	0.051	1.30
7 to 20 ⁽¹⁾	17 to 50 ⁽¹⁾	X	X	1N3112X0012	Unpainted	2.18	55.4	0.075	1.90
16 to 40 ⁽¹⁾	40 to 99 ⁽¹⁾	X	X	1B413727222	Purple	2.12	53.8	0.092	2.34
1 to 3.25 psig	69 mbar to 0.22 bar	X	X	T13593T0012	Light blue	2.12	53.8	0.105	2.67
2.75 to 6 psig	0.19 to 0.41 bar	X	X	T13671T0012	Orange	2.40	61.0	0.120	3.05
5 to 16 psig	0.34 to 1.1 bar	X	X	T13600T0012	Red	2.10	53.3	0.142	3.61
14 to 35 psig	0.97 to 2.4 bar	X	X	19B0432X012	Zinc	2.15	54.6	0.207	5.26
30 to 60 psig	2.1 to 4.1 bar	X	X	19B0432X022	Green	2.75	69.8	0.225	5.71

1. Use a pilot supply regulator if actual inlet pressure varies more than ± 20 psi / ± 1.4 bar and the published accuracy is required.

- **Startup Protection**—The main valve and the pilot are designed with reverse pressure mechanisms to prevent damage during startup or sudden increase in downstream pressure.
- **Fewer Parts**—Fewer recommended parts needed for spare parts inventory.

Introduction

Description

▲ WARNING

Since a pilot-operated regulator is constructed of both a pilot and a main valve, do not exceed the maximum inlet pressure shown on the nameplate.

The 299H Series pressure reducing regulators provide a broad capacity of controlled pressure ranges and capacities in a wide variety of distribution, industrial and commercial applications. A 299H Series regulator has a pilot integrally mounted to the actuator casing. The 299H Series regulators can handle inlet pressures up to 175 psig / 12.1 bar depending on orifice size.

The integral token relief on the Types 299HR and 299HVR regulators is located in the pilot and alerts you to an increase in downstream pressure beyond the regulator setpoint.

The Type 299HV provides overpressure or overpressure and underpressure protection by completely shutting off the flow of gas to the downstream system. It comes with a Type VSX8 (299HV) slam-shut device which can be configured for Overpressure Shutoff (OPSO) or Overpressure and Underpressure Shutoff (OPSO/UPS0). The slam-shut device's actions are independent of the main valve and of variations to the inlet pressure. The Type VSX8 (299HV) slam-shut device has internal or external registration. External registration requires a downstream sensing line.

Options

P590 Series Pilot Supply Filter

The optional P590 Series pilot supply filter prevents pipeline debris from entering the pilot; a primary cause of pilot clogging. When the upstream system is free of debris, the 299H Series regulators may be installed without a pilot supply filter.

Type 67CF Filtered Pilot Supply Regulator

When it is necessary to install a pilot supply regulator, an optional Type 67CF filtered pilot supply regulator may be installed. For example, on applications with in. of water column setpoints and inlet pressure variations of more than ± 20 psig / ± 1.4 bar, it may be necessary to install a Type 67CF to maintain published accuracy.



299H Series

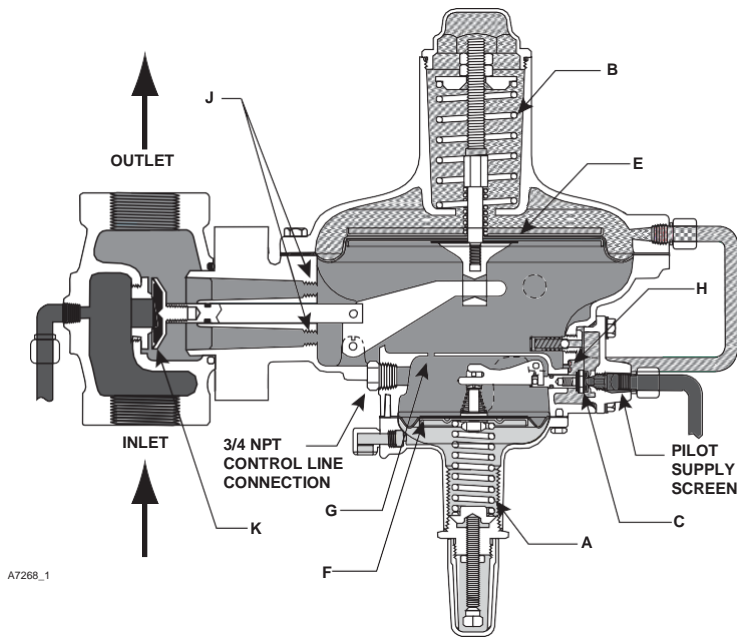

A7268_1

TYPE 299H WITH INTERNAL REGISTRATION

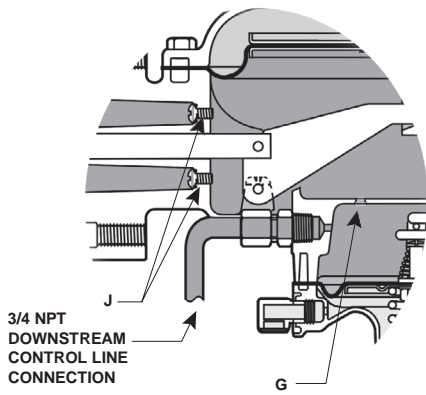

A7269

EXTERNAL REGISTRATION

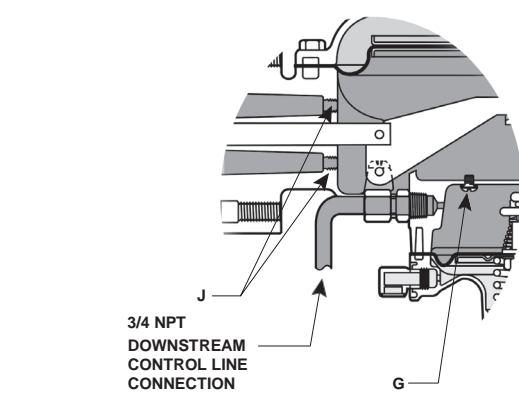

A7270

DUAL REGISTRATION

- INLET PRESSURE
- OUTLET PRESSURE
- ATMOSPHERIC PRESSURE
- LOADING PRESSURE

Figure 3. Type 299H Operational Schematic



299H Series

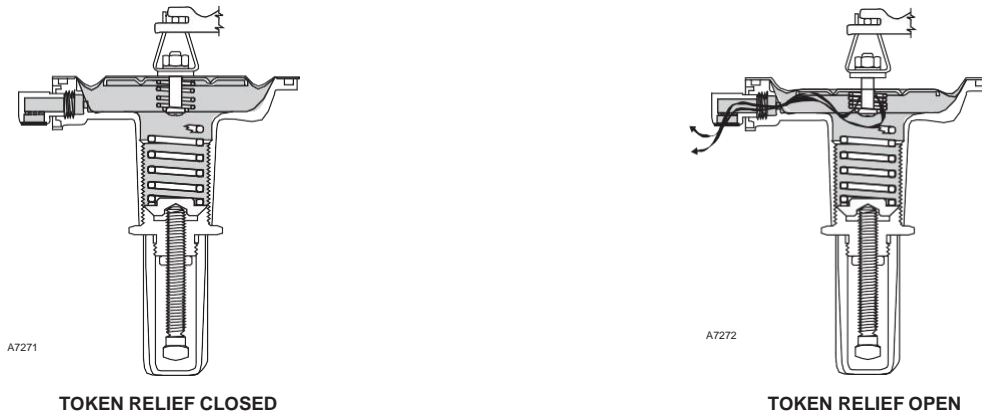
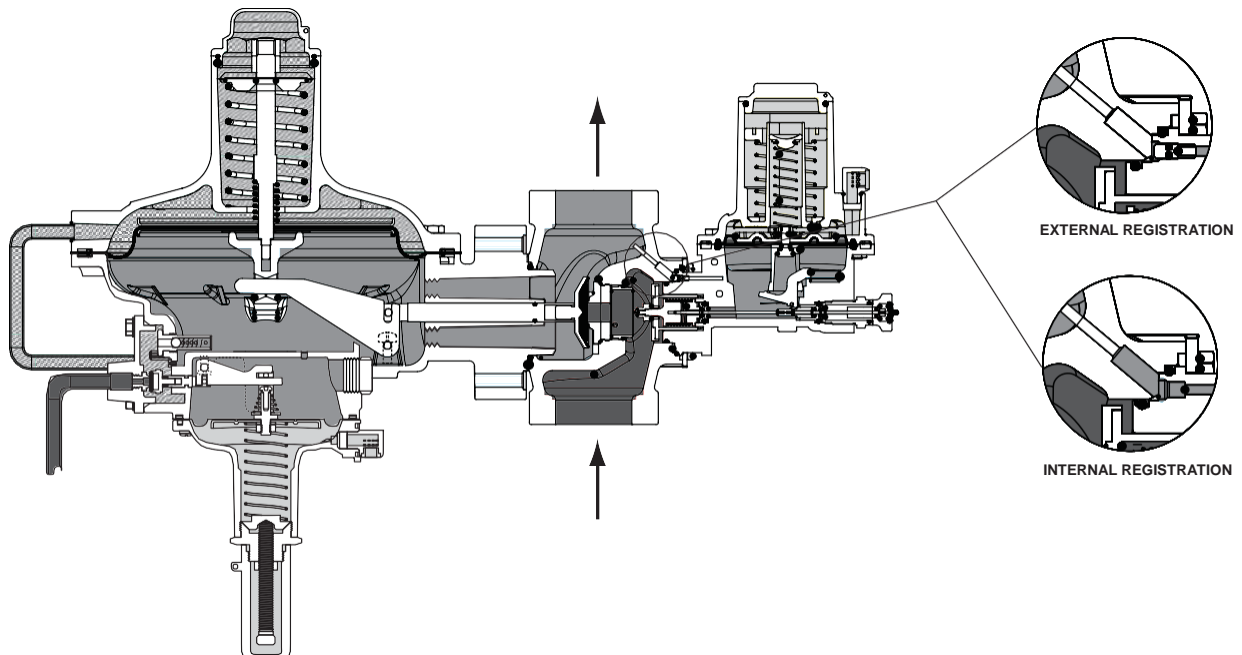

Figure 4. Type 299HR Operational Schematic



E0072_05/2017

- INLET PRESSURE
- OUTLET PRESSURE
- ATMOSPHERIC PRESSURE
- LOADING PRESSURE

Figure 5. Type 299HV Operational Schematic



299H Series

Reed Switch

An optional remote notification switch can be installed offering the capability to remotely notify the operator should VSX8 Series shut off occur. Reed switch is available on our regulators 299HV and 299HVR Series only. Reference D103127X012 for instruction manual.

Principle of Operation

Letter keys in this section refer to Figure 3 unless otherwise noted. Fast response and accuracy are made possible by the amplifying effect of the pilot and by the two-path control system. The function of the pilot is to sense change in the controlled outlet pressure and amplify it into a larger change in the loading pressure. Any changes in outlet pressure act quickly on both the actuator diaphragm and the loading pilot, thus providing the precise pressure control and fast speed of response that is characteristic of a two-path system.

Upstream or inlet pressure is utilized as the operating medium, which is reduced through pilot operation to load the main diaphragm chamber. Tubing connects the inlet pressure to the pilot. Downstream or outlet pressure registers underneath main diaphragm (E) and on top of pilot diaphragm (F). There are three different versions of pressure registration for the Type 299H.

Internal registration (screws and O-rings (J) removed)—Outlet pressure is registered through the throat to the main diaphragm chamber and through a small port (G) to the top of the pilot diaphragm. Internal registration is used for ease of installation. Capacity is somewhat limited because of droop and/or boost associated with sensing pressure within the body.

External registration—Screws and O-rings (J) block the throat and a downstream control line is connected to the pilot diaphragm chamber which is connected to the lower main diaphragm chamber by a small port (G). The other end of the control line connects to the downstream pipeline. External registration is used for higher capacity and/or the upstream regulator in a monitor set. It also allows monitoring for inlet pressures over 66 psig/ 4.5 bar. Capacity is increased because of better registration of pipeline pressure when a control line is used. The alternate 3/4 NPT control line connection (on the side of the pilot) can be used for piping convenience, see Figures 8 and 9.

Dual registration (screws and O-rings (J) removed)—

The lower main diaphragm chamber registers outlet pressure through the throat and the pilot diaphragm chamber registers downstream pressure by use of a downstream control line. The port (G) between the chambers is blocked by inserting a screw and O-ring (J) that was removed from the throat and the control line runs from the pilot to the downstream pipeline. Dual registration, with its larger orifice (control line must be piped to the primary 3/4 NPT connection on the side of the pilot), provides an improved performance as compared to internal pressure registration when used in low flow rate and high pressure drop applications. It is also used for no downstream bleed monitoring systems with inlet pressures up to 66 psig / 45 bar.

Type 299H

In operation, assume the outlet pressure is less than the setting of pilot control spring (A). The top side of pilot diaphragm assembly (F) will have a lower pressure than the setting of spring (A). Spring (A) forces the diaphragm assembly upward, opening the pilot orifice (C). Additional loading pressure is supplied to the top side of the main diaphragm (E).

This creates a higher pressure on the top side of main diaphragm (E) than on the bottom side, forcing the diaphragm downward. This motion is transmitted through a lever, which pulls the valve disk (K) open, allowing more gas to flow through the valve.

When the gas demand in the downstream system has been satisfied, the outlet pressure increases. The increased pressure is transmitted through the downstream control line (for external or dual registration) or through the port (G) (for internal registration) and acts on top of the pilot diaphragm (F). This pressure exceeds the pilot spring setting and forces the diaphragm down, closing the orifice (C). The loading pressure acting on main diaphragm (E) bleeds to the downstream system through a bleed restriction (H).

With a decrease in loading pressure on top of main diaphragm (E), main spring (B) exerts an upward force on the diaphragm post connected to main diaphragm (E), pulling it upward. This moves the main valve disk (K) toward its seat, decreasing flow to the downstream system.



299H Series

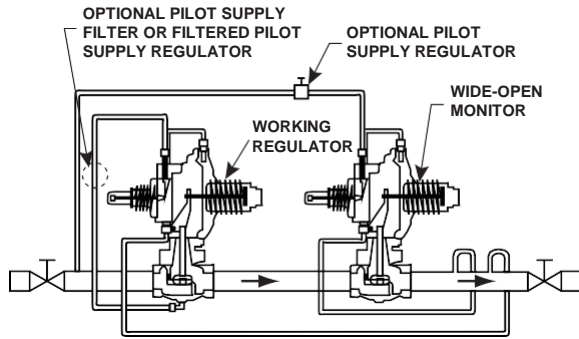

A7136A

NOTE: IF USED, THE PILOT SUPPLY REGULATOR SHOULD BE SET TO 3 psig / 0.21 bar ABOVE THE MONITOR OUTLET PRESSURE SETTING.

WIDE-OPEN DOWNSTREAM MONITOR

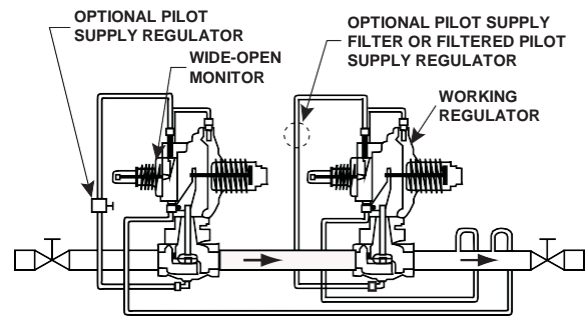

A7136B

NOTE: IF USED, THE PILOT SUPPLY REGULATOR SHOULD BE SET TO 3 psig / 0.21 bar ABOVE THE MONITOR OUTLET PRESSURE SETTING.

WIDE-OPEN UPSTREAM MONITOR

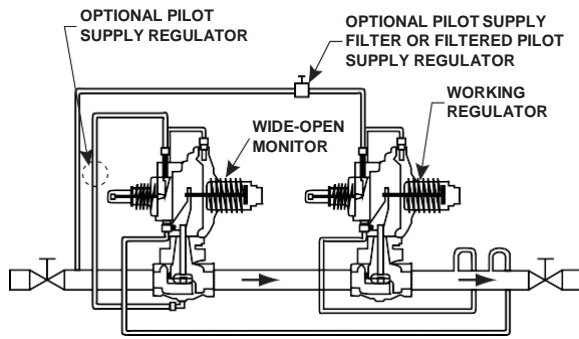

A7136C

NOTE: THE PILOT SUPPLY REGULATOR SHOULD BE SET TO 3 psig / 0.21 bar ABOVE THE MONITOR OUTLET PRESSURE SETTING.

WIDE-OPEN UPSTREAM MONITOR

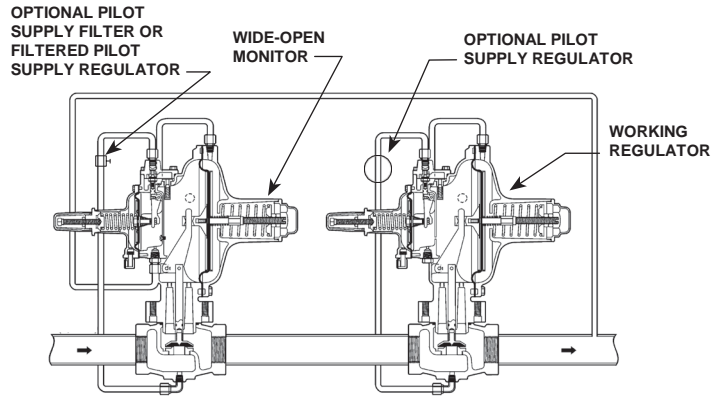

A7273

NOTE: THE PILOT SUPPLY REGULATOR SHOULD BE SET TO 3 psig / 0.21 bar ABOVE THE MONITOR OUTLET PRESSURE SETTING.

NO DOWNSTREAM BLEED MONITOR SYSTEM

Figure 6. Typical Monitor Installations

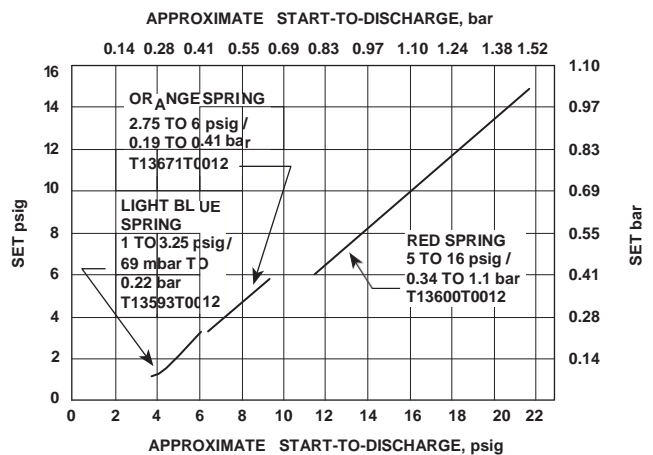
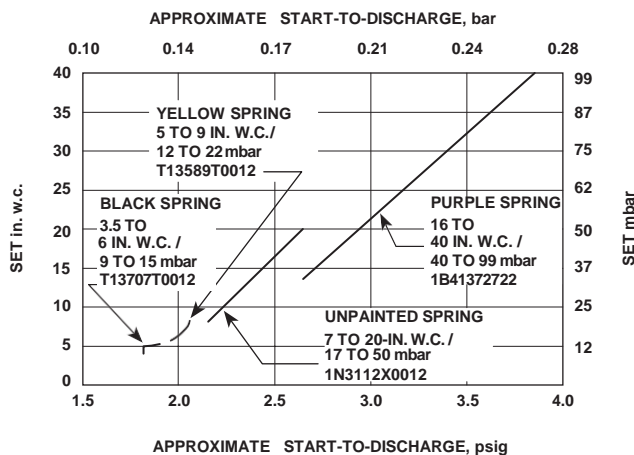

Figure 7. Type 299HR Approximate Start-to-Discharge



299H Series

Type 299HR

Refer to Figure 4. The Type 299HR provides an integral token relief valve. During an overpressure condition the spring on the pilot post will allow the diaphragm head to travel to the spring case. As the diaphragm head moves a small amount of gas is relieved.

Note

The Type 299HR is not a full capacity relief device. Approximate start-to-discharge pressure is dependent on set pressure, see Figure 7.

During normal operation the Type 299HR performance is identical to the Type 299H. If an overpressure condition occurs, the pilot diaphragm head will separate from the pilot diaphragm post and travel until it contacts the pilot spring case. The movement of the diaphragm head creates a path and a token or noticeable amount of gas will be released.

When the overpressure condition ceases, the pilot diaphragm head will return to the diaphragm post and the regulator will return to normal operation.

Type 299HV

Refer to Figure 5. The Type VSX8 (299HV) slam-shut devices on the Type 299HV regulator is a fast acting slam-shut valve which provides overpressure or overpressure and underpressure protection by completely shutting off the flow of gas to the downstream system. The slam-shut modules' actions are independent of the Type 299HV main regulator and of variations to the inlet pressure. The Type VSX8 (299HV) has internal or external registration. External registration requires a downstream sensing line.

The slam-shut disk is held in the open position (reset position) by an internal latching mechanism that holds the valve stem and disk assembly. If the pressure below the diaphragm increases (or decreases) reaching the Type VSX8 (299HV) setpoint, the diaphragm will travel upwards (or downwards) operating a lever which in turn releases the valve stem assembly.

Once released, the spring force on the stem will push the stem and disk to the closed position against the seat shutting off all gas flow. The pilot supply pressure is also shut off when the Type VSX8 (299HV) is closed. The manual reset has an internal bypass to equalize the reset pressure on either side on the slam-shut disk.

In order for the Underpressure Shutoff (UPSO) of any slam shut to be triggered, the downstream pipe pressure must drop below the UPSO setpoint. In the case of a downstream line break, numerous factors can prevent the downstream pipe pressure from decreasing below the slam-shut UPSO setpoint. These factors include the distance of pipe to the break, the diameter of the pipe, size of the break and the number of restrictions, such as valves, elbows and bends, downstream of the regulator and/or slam-shut device. Due to these factors, additional protections should be installed to stop flow in the event of a line break.

Overpressure Protection

Like most regulators, the Type 299H has outlet pressure ratings lower than the inlet pressure ratings. Complete downstream overpressure protection is needed if the actual inlet pressure exceeds the outlet pressure rating.

Overpressure protection for internal parts is built into the main and pilot diaphragms by means of a small spring on each post. The springs will allow the diaphragm heads to move farther on the posts avoiding damage to or bending of the valve trim.

Overpressuring any portion of a regulator or associated equipment may cause leakage, parts damage or personal injury due to bursting of pressure-containing parts or explosion of accumulated gas. Regulator operation within ratings specified in the Specifications section and on the regulator nameplate does not preclude the possibility of damage from external sources or from debris in the pipeline. A regulator should be inspected for damage periodically and after any overpressure condition. The pilot vent is provided with a 1/4 NPT tapped connection in the spring case.



299H Series

Table 3. Flow Coefficients

TYPE	ORIFICE DIAMETER		WIDE-OPEN			REGULATING ⁽¹⁾		
	In.	mm	C _g	C _v	C _i	C _g	C _v	C _i
299H/299HR	1/4 x 3/8	6.4 x 9.5	53	2.0	27	50	1.9	26
	3/8	9.5	117	4.2	28	115	4.0	29
	1/2	13	203	7.0	29	200	9.6	21
	3/4	19	437	14.1	31	430	13.9	31
	7/8	22	544	16.5	33	534	16.2	33
	1	25	725	20.7	35	710	20.3	35
	1-3/16	30	910	25.3	36	885	24.6	36
299HV and 299HVR	1/4 x 3/8	6.4 x 9.5	53	2.0	27	50	1.9	26
	3/8	9.5	117	4.1	29	115	4.0	29
	1/2	13	184	5.0	37	180	4.9	37
	3/4	19	421	11.9	35	415	11.7	35
	7/8	22	544	15.3	36	528	14.8	36
	1	25	648	17.3	38	628	16.8	38
	1-3/16	30	740	19.1	39	717	18.5	39

1. For external/dual registration only.

Table 4a. Type VSX8 High and Low Trip Pressure Ranges (North American Overpressure Shut-off OPSO Ranges Only)

REGULATOR			SLAM SHUT DEVICE				
Type Number	Typical Setpoint	Spring Range	Type Number	OPSO		OPSO ⁽¹⁾ Typical Set	
				Set Range Over UPSO Setpoint	Spring Part Number and Color		
	In. w.c.	In. w.c.		In. w.c.		In. w.c.	
299HV 299HVR	4.0	3.5 to 6.0	VSX8L	12.0 to 24.0	GF02168X012 Brown	19.0	
	7.0	5.0 to 9.0			GF02169X012 Red	22.0	
	11.0	7.0 to 20.0		16.0 in. w.c. to 1.6 psig	GF02169X012 Red	25.0	
	14.0			24.0 in. w.c. to 2.8 psig	GF02170X012 Orange	1.1 psig	
	1 psig	16.0 in. w.c. to 1.4 psig		2.0 to 7.3 psig	GF02172X012 Green	2.0 psig	2.0 psig
	2.0 psig	1.0 to 3.3 psig				3.5 psig	
	3.0 psig	2.8 to 6.0 psig		3.2 to 11.0 psig	GF02173X012 Silver	5.0 psig	7.0 psig
	5.0 psig					12.0 psig	
	10.0 psig	5.0 to 16.0 psig		5.8 to 21.0 psig	GF04353X012 Yellow	19.0 psig	19.0 psig
	15.0 psig						

1. For units equipped with Token Relief, if Non-Factory Slam-shut OPSO setpoints are specified, they must be higher than the Token Relief Start-to-Discharge values provided in Table 5. Note: Other spring combinations are available. Please contact your local Sales Office for additional information.

Table 4b. Type VSX8 High and Low Trip Pressure Ranges (European Overpressure Shut-off OPSO Ranges Only)

REGULATOR			SLAM SHUT DEVICE				
Type Number	Typical Setpoint	Spring Range	Type Number	OPSO		OPSO ⁽¹⁾ Typical Set	
				Set Range Over UPSO Setpoint	Spring Part Number and Color		
	mbar	mbar		mbar		mbar	
299HV 299HVR	21	12 to 22	VSX8L	30 to 60	GF02168X012 Brown	45	
	35	17 to 50		40 to 110	GF02169X012 Red	67	
	50	40 to 100		60 to 190	GF02170X012 Orange	90	
	60					104	
	75					128	
	100	70 to 224		140 to 500	GF02172X012 Green	170	248
	150			220 to 760	GF02173X012 Silver	450	
	300			190 to 414	GF04353X012 Yellow	700	
	500	345 to 1103		400 to 1450			

1. For units equipped with Token Relief, if Non-Factory Slam-shut OPSO setpoints are specified, they must be higher than the Token Relief Start-to-Discharge values provided in Table 5. Note: Other spring combinations are available. Please contact your local Sales Office for additional information.



299H Series

Table 4c. Type VSX8 High and Low Trip Pressure Ranges (North American Overpressure and Underpressure Shut-off UPSO/OPSO Ranges)

REGULATOR			SLAM SHUT DEVICE							
Type Number	Typical Setpoint	Spring Range	Type Number	UPSO		OPSO		Typical Set		
	In. w.c.	In. w.c.		Set Range ⁽¹⁾	Spring Part Number and Color	Set Range Over UPSO Setpoint	Spring Part Number and Color	UPSO	Adjusted OPSO Range	OPSO ⁽²⁾
				In. w.c.	In. w.c.	In. w.c.	In. w.c.	In. w.c.	In. w.c.	
299HV 299HVR	7.0 ⁽³⁾	5.0 to 9.0	VSX8L	3.0 to 12.0	ERAA05835A0 White	18 in. w.c. to 1.1 psig	GF02168X012 Brown	3 ⁽³⁾	21 in. w.c. to 1.2 psig	22.0
	11.0 ⁽³⁾	7.0 to 20.0						6 ⁽³⁾	24 in. w.c. to 1.3 psig	25.0
	14.0 ⁽³⁾			4.0 in. w.c. to 1.1 psig	T14169T0012 Blue	25 in. w.c. to 1.9 psig	GF02169X012 Red	9 ⁽³⁾	27 in. w.c. to 1.3 psig	1.1 psig
	1.0 psig ⁽³⁾	16.0 in. w.c. to 1.4 psig		10.0 in. w.c. to 2.3 psig	T14170T0012 Silver	1.2 to 3.2 psig	GF02170X012 Orange	14 ⁽³⁾	1.4 to 2.4 psig	2.0 psig
	2.0 psig ⁽⁴⁾	1.0 psig to 3.3 psig		1.5 to 7.3 psig	FA142869X12 Orange Stripe	2.6 to 5.6 psig	GF02171X012 Pink	1.0 psig ⁽⁴⁾	2.2 to 4.2 psig	3.5 psig
	3.0 psig ⁽⁴⁾	2.8 to 6.0 psig						2.0 psig ⁽⁴⁾	4.4 to 7.4 psig	5.0 psig
	5.0 psig ⁽⁴⁾	5.0 to 16.0 psig		3.5 to 8.2 psig	GF02172X012 Green	3.0 psig ⁽⁴⁾	6.5 to 11.2 psig	7.0 psig		
	10.0 psig ⁽⁵⁾					5.0 psig ⁽⁵⁾	10.5 to 15.2 psig	12 psig		
	15.0 psig ⁽⁵⁾			1.5 to 10.9 psig	T14171T0012 Olive	6.7 to 13.5 psig	GF02173X012 Silver	7.0 psig ⁽⁵⁾	13.7 to 20.5 psig	19.0 psig

1. If Non-Factory UPSO setpoints are specified, a minimum differential of 4 in. w.c. between UPSO setpoint and regulator setpoint must be maintained in order to ensure a secure latch of the Slam-Shut.

2. For units equipped with Token Relief, if Non-Factory Slam-shut OPSO setpoints are specified, they must be higher than the Token Relief Start-to-Discharge values provided in Table 5.

3. For an internally registered Type VSX8, UPSO cannot be used with this main valve spring range to provide underpressure shutoff under flowing conditions. If protection against loss of inlet pressure is the only required function for the Type VSX8 then an internally registered Type VSX8 may be used with the same minimum trip pressures as an externally registered Type VSX8.

4. For an internally registered Type VSX8, 70% of regulator setpoint is the minimum allowable UPSO setting used with this main valve spring range. If protection against loss of inlet pressure is the only required function for the Type VSX8 then an internally registered Type VSX8 may be used with the same minimum trip pressures as an externally registered Type VSX8.

5. For an internally registered Type VSX8, 75% of regulator setpoint is the minimum allowable UPSO setting used with this main valve spring range. If protection against loss of inlet pressure is the only required function for the Type VSX8 then an internally registered Type VSX8 may be used with the same minimum trip pressures as an externally registered Type VSX8.

Note: Other spring combinations are available. Please contact your local Sales Office for additional information.



299H Series

Table 4d. Type VSX8 High and Low Trip Pressure Ranges (European Overpressure and Underpressure Shut-off UPSO/OPSO Ranges)

REGULATOR			SLAM SHUT DEVICE							
Type Number	Typical Setpoint, mbar	Spring Range, mbar	Type Number	UPSO		OPSO		Typical Set		
				Set Range ⁽¹⁾	Spring Part Number and Color	Set Range Over UPSO Setpoint	Spring Part Number and Color	UPSO	Adjusted OPSO Range	OPSO ⁽²⁾
				mbar		mbar				
299HV 299HVR	21 ⁽³⁾	12 to 22	VSX8L	7 to 30	ERAA05835A0 White	40 to 55	GF02167X012 Black	10 ⁽³⁾	50 to 65	55
	35 ⁽³⁾	17 to 50				45 to 76		18 ⁽³⁾	63 to 94	67
	50 ⁽³⁾	40 to 100		10 to 75	T14169T0012 Blue	50 to 80	GF02168X012 Brown	25 ⁽³⁾	75 to 105	90
	60 ⁽³⁾					62 to 132	GF02169X012 Red	38 ⁽³⁾	100 to 170	128
	75 ⁽³⁾			70 to 224	25 to 160	T14170T0012 Silver	83 to 221	GF02170X012 Orange	50 ⁽⁴⁾	133 to 271
	100 ⁽⁴⁾	100 to 500					FA142869X12 Orange Stripe	179 to 386	GF02171X012 Pink	150 ⁽⁴⁾
	150 ⁽⁴⁾	345 to 1103			100 to 750	T14171T0012 Olive	460 to 932	GF02173X012 Silver	250 ⁽⁵⁾	710 to 1182
	300 ⁽⁴⁾			190 to 414					500 ⁽⁵⁾	960 to 1432
	500 ⁽⁵⁾									
	1000 ⁽⁵⁾									

1. If Non-Factory UPSO setpoints are specified, a minimum differential of 10 mbar between UPSO setpoint and regulator setpoint must be maintained in order to ensure a secure latch of the Slam-Shut.

2. For units equipped with Token Relief, if Non-Factory Slam-shut OPSO setpoints are specified, they must be higher than the Token Relief Start-to-Discharge values provided in Table 5.

3. For an internally registered Type VSX8, UPSO cannot be used with this main valve spring range to provide underpressure shutoff under flowing conditions. If protection against loss of inlet pressure is the only required function for the Type VSX8 then an internally registered Type VSX8 may be used with the same minimum trip pressures as an externally registered Type VSX8.

4. For an internally registered Type VSX8, 70% of regulator setpoint is the minimum allowable UPSO setting used with this main valve spring range. If protection against loss of inlet pressure is the only required function for the Type VSX8 then an internally registered Type VSX8 may be used with the same minimum trip pressures as an externally registered Type VSX8.

5. For an internally registered Type VSX8, 75% of regulator setpoint is the minimum allowable UPSO setting used with this main valve spring range. If protection against loss of inlet pressure is the only required function for the Type VSX8 then an internally registered Type VSX8 may be used with the same minimum trip pressures as an externally registered Type VSX8.

Note: Other spring combinations are available. Please contact your local Sales Office for additional information.



299H Series

Monitoring Systems

Monitoring regulators serve as overpressure protection devices to limit system pressure in the event of open failure of a working regulator feeding the system.

Wide-Open Monitor

The control line of the upstream regulator is connected downstream of the second regulator (Figure 6), so that during normal operation the monitoring regulator is standing wide open with the reduction to distribution pressure being taken across the working regulator. Only in case of open failure of the working regulator does the wide-open monitoring regulator take control at its slightly higher setting. A pressure build-up above the monitor set pressure is required for the monitor to take control in the event of an overpressure situation. Installing a pilot supply regulator on the monitor will minimize the pressure build-up. The pilot supply regulator should be set to 3 psig / 0.21 bar above the monitor setpoint.

The minimum set pressure difference between the worker and monitor should be greater than the proportional band. Small set pressure differences may cause the worker and monitor to function independently.

The upstream regulator can easily be field converted or ordered with screws and O-rings in the throat (Figure 6). This seals off the path that otherwise would let line pressure ahead of the working regulator inlet and try to close the wide-open monitoring regulator.

No Downstream Bleed Monitor

The no bleed monitor is a wide-open upstream monitor which works like a conventional wide-open upstream monitor except for registration. The no bleed monitor utilizes a dual registration construction as opposed to the external registration construction of the conventional monitor. This ensures that the lockup of the monitor system is the lockup of the downstream working monitor at zero flow during normal operation.

Installation

Although the actuator and pilot can be mounted in 90° increments relative to the body, the normal installation is with the body in a horizontal run of pipe and the pilot hanging vertically from the bottom of the actuator.

Control and vent lines necessary for installation are not supplied with a Type 299H regulator. Control and vent connection locations are shown in Figures 8 and 9. In many instances good piping practice will require that outlet piping be swaged up above the body size to prevent excessive pressure drop along the outlet

Capacity Information

Tables 5 through 10 give the 299H Series natural gas regulating capacities at selected inlet pressures and outlet pressure settings. Flows are in SCFH (60°F and 14.7 psig) and Nm³/h (0°C and 1.01325 bar) of 0.6 specific gravity natural gas. To determine equivalent capacities for air, propane, butane or nitrogen, multiply the capacity number in the Tables by the following appropriate conversion factor: 0.775 for air, 0.628 for propane, 0.548 for butane or 0.789 for nitrogen. For gases of other specific gravities, multiply the given capacity by 0.775 and divide by the square root of the appropriate specific gravity.

For critical flow:

To determine wide-open flow capacities for relief sizing of 0.6 specific gravity natural gas at 60°F at critical pressure drops (absolute outlet pressure equal to approximately one-half or less than one-half of the absolute inlet pressure), use the following formula:

$$Q = P_{1(abs)}(C_g)(1.29)$$

For subcritical flow:

If pressure drops are lower than critical (absolute outlet pressure greater than approximately one-half the absolute inlet pressure), use the following formula and convert according to the factors in the preceding paragraph if necessary:

$$Q = \sqrt{\frac{520}{GT}} C P \sin \left[\frac{3417}{C_1} \sqrt{\frac{\Delta P}{P_1}} \right] \text{ DEG}$$

where:

line. The piping should be expanded as close to the regulator outlet as possible.



บริษัท เอดีดี เฟอร์เนส จำกัด

ADD FURNACE CO.,LTD.

44 ซอยบรมราชชนนี 70 ถนนบรมราชชนนี แขวงศาลาธรรมสพน์ เขตทวีวัฒนา กรุงเทพฯ 10170

โทร: 02-888-3472 โทร: ออกแบบ:08-08-170-170 แฟกซ์: 02-888-3258

<https://www.add-furnace.com> E-mail: sales@add-furnace.com

299H Series

$C_1 = C_g/C_v$ (see Table 3)

C_g = Gas sizing coefficient (see Table 3)

G = Gas specific gravity (air = 1.0)

P_1 = Regulator inlet pressure, psia

ΔP = Pressure drop across regulator, psi

Q = Gas flow rate, SCFH

T = Absolute temperature of gas at inlet,
°Rankine

Note

**Due to boost, the above formulas
cannot be used to obtain correct
regulating capacities for regulators
with internal registration.**

The published capacities were obtained using inlet
and
outlet piping the same size as the regulator body
size.



299H Series

Table 5. Types 299H and 299HR Flow Capacities⁽¹⁾ for 1-1/2 NPT and NPS 2 / DN 50 External/Dual Registration

OUTLET PRESSURE RANGE SETTING, ACCURACY, SPRING PART NUMBER AND COLOR	INLET PRESSURE		CAPACITIES IN SCFH / Nm ³ /h OF 0.6 SPECIFIC GRAVITY NATURAL GAS													
			Orifice Size, In. / mm													
			1/4 x 3/8 / 6.4 x 9.5		3/8 / 9.5		1/2 / 13		3/4 / 19		7/8 / 22		1 / 25		1-3/16 / 30	
	psig	bar	SCFH	Nm ³ /h	SCFH	Nm ³ /h	SCFH	Nm ³ /h	SCFH	Nm ³ /h	SCFH	Nm ³ /h	SCFH	Nm ³ /h	SCFH	Nm ³ /h
3.5 to 6 in. w.c. / 9 to 15 mbar 3.5 in. w.c. / 9 mbar -1 to 2 in. w.c. / -2 to 5 mbar T13707T0012 Black	2	0.14	760	20.4	1560	41.8	2700	72.4	5490	147	6460	173	8170	219	9940	266
	5	0.34	1160	31.1	2460	65.9	4270	114	8790	236	10,350	277	13,310	357	16,250	436
	10	0.69	1590	42.6	3580	95.9	6230	167	13,060	350	15,270	409	20,300	544	24,900	667
	15	1.0	1920	51.4	4410	118	7670	206	16,480	442	19,450	521	25,780	691	31,730	850
	20	1.4	2240	60.0	5150	138	8960	240	19,250	516	24,110	646	31,790	852	39,620	1062
	25	1.7	2570	68.9	5890	158	10,250	275	22,030	590	27,110	727	36,370	975	45,330	1215
	30	2.1	2890	77.4	6640	178	11,540	309	24,800	665	31,110	834	40,950	1097	51,040	1368
	40	2.8	3530	94.6	8120	218	14,120	378	30,350	813	38,100	1021	50,100	1343	62,450	1674
	50	3.4	4180	112	9600	257	16,700	448	35,890	962	44,100	1182	59,260	1588	73,870	1980
	60	4.1	4820	129	11,090	297	19,280	517	41,440	1111	51,090	1369	68,420	1834	85,290	2286
	80	5.5	6110	164	14,050	377	24,440	655	52,540	1408	65,080	1744	86,740	2325	108,120	2898
	100	6.9	7400	198	17,020	456	29,600	793	63,630	1705	79,060	2119	105,060	2816		
	125	8.6	9020	242	20,730	556	36,050	966	77,500	2077	96,050	2574				
	150	10.3	10,630	285	24,440	655	42,500	1139	91,360	2448						
	175	12.1	12,240	328	28,150	754	48,950	1312								
5 to 9 in. w.c. / 12 to 22 mbar 7 in. w.c. / 17 mbar -1 to 2 in. w.c. / -2 to 5 mbar T13589T0012 Yellow	2	0.14	750	20.1	1520	40.7	2650	71.0	5380	144	6270	168	8000	214	9730	261
	5	0.34	1160	31.1	2440	65.4	4240	114	8730	234	10,250	275	13,220	354	16,130	432
	10	0.69	1590	42.6	3580	95.9	6220	167	13,040	349	15,220	408	20,250	543	24,830	665
	15	1.0	1920	51.4	4410	118	7670	206	16,480	442	19,420	520	25,750	690	31,690	849
	20	1.4	2240	60.0	5150	138	8960	240	19,250	516	24,110	646	31,790	852	39,620	1062
	25	1.7	2570	68.9	5890	158	10,250	275	22,030	590	27,110	727	36,370	975	45,330	1215
	30	2.1	2890	77.4	6640	178	11,540	309	24,800	665	31,110	834	40,950	1097	51,040	1368
	40	2.8	3530	94.6	8120	218	14,120	378	30,350	813	38,100	1021	50,100	1343	62,450	1674
	50	3.4	4180	112	9600	257	16,700	448	35,890	962	44,100	1182	59,260	1588	73,870	1980
	60	4.1	4820	129	11,090	297	19,280	517	41,440	1111	51,090	1369	68,420	1834	85,290	2286
	80	5.5	6110	164	14,050	377	24,440	655	52,540	1408	65,080	1744	86,740	2325	108,120	2898
	100	6.9	7400	198	17,020	456	29,600	793	63,630	1705	79,060	2119	105,060	2816		
	125	8.6	9020	242	20,730	556	36,050	966	77,500	2077	96,050	2574				
	150	10.3	10,630	285	24,440	655	42,500	1139	91,360	2448						
	175	12.1	12,240	328	28,150	754	48,950	1312								
7 to 20 in. w.c. / 17 to 50 mbar 14 in. w.c. / 35 mbar ±2 in. w.c. / ±5 mbar 1N3112X0012 Unpainted	2	0.14	700	18.8	1430	38.3	2480	66.5	5040	135	5850	157	7480	200	9090	244
	5	0.34	1140	30.5	2400	64.3	4170	112	8570	230	10,040	269	12,950	347	15,800	423
	10	0.69	1580	42.3	3560	95.4	6190	166	12,970	348	15,110	405	20,110	539	24,640	660
	15	1.0	1920	51.4	4410	118	7670	206	16,480	442	19,350	519	25,660	688	31,560	846
	20	1.4	2240	60.0	5150	138	8960	240	19,250	516	24,110	646	31,790	852	39,620	1062
	25	1.7	2570	68.9	5890	158	10,250	275	22,030	590	27,110	727	36,370	975	45,330	1215
	30	2.1	2890	77.4	6640	178	11,540	309	24,800	665	31,110	834	40,950	1097	51,040	1368
	40	2.8	3530	94.6	8120	218	14,120	378	30,350	813	38,100	1021	50,100	1343	62,450	1674
	50	3.4	4180	112	9600	257	16,700	448	35,890	962	44,100	1182	59,260	1588	73,870	1980
	60	4.1	4820	129	11,090	297	19,280	517	41,440	1111	51,090	1369	68,420	1834	85,290	2286
	80	5.5	6110	164	14,050	377	24,440	655	52,540	1408	65,080	1744	86,740	2325	108,120	2898
	100	6.9	7400	198	17,020	456	29,600	793	63,630	1705	79,060	2119	105,060	2816		
	125	8.6	9020	242	20,730	556	36,050	966	77,500	2077	96,050	2574				
	150	10.3	10,630	285	24,440	655	42,500	1139	91,360	2448						
	175	12.1	12,240	328	28,150	754	48,950	1312								
16 to 40 in. w.c. / 40 to 99 mbar 28 in. w.c. / 70 mbar ±4 in. w.c. / ±10 mbar 1B413727222 Purple	5	0.34	1110	29.7	2320	62.2	4020	108	8250	221	9580	257	12,430	333	15,150	406
	10	0.69	1570	42.1	3530	94.6	6140	165	12,830	344	14,870	399	19,830	531	24,290	651
	15	1.0	1920	51.4	4410	118	7670	206	16,170	433	19,220	515	25,480	683	31,320	839
	20	1.4	2240	60.0	5150	138	8960	240	19,250	516	24,110	646	30,670	822	37,820	1014
	25	1.7	2570	68.9	5890	158	10,250	275	22,030	590	27,110	727	36,370	975	45,330	1215
	30	2.1	2890	77.4	6640	178	11,540	309	24,800	665	31,110	834	40,950	1097	51,040	1368
	40	2.8	3530	94.6	8120	218	14,120	378	30,350	813	38,100	1021	50,100	1343	62,450	1674
	50	3.4	4180	112	9600	257	16,700	448	35,890	962	44,100	1182	59,260	1588	73,870	1980
	60	4.1	4820	129	11,090	297	19,280	517	41,440	1111	51,090	1369	68,420	1834	85,290	2286
	80	5.5	6110	164	14,050	377	24,440	655	52,540	1408	65,080	1744	86,740	2325	108,120	2898
	100	6.9	7400	198	17,020	456	29,600	793	63,630	1705	79,060	2119	105,060	2816		
	125	8.6	9020	242	20,730	556	36,050	966	77,500	2077	96,050	2574				
	150	10.3	10,630	285	24,440	655	42,500	1139	91,360	2448						
	175	12.1	12,240	328	28,150	754	48,950	1312								

- Blank areas indicate where maximum operating inlet pressure for a given orifice size is exceeded.

1. Downstream piping may affect actual capacity. It may be necessary to use enlarged downstream piping to obtain published capacities.



299H Series

Table 5. Types 299H and 299HR Flow Capacities⁽¹⁾ for 1-1/2 NPT and NPS 2 / DN 50 External/Dual Registration (continued)

OUTLET PRESSURE RANGE SETTING, ACCURACY, SPRING PART NUMBER AND COLOR	INLET PRESSURE		CAPACITIES IN SCFH / Nm ³ /h OF 0.6 SPECIFIC GRAVITY NATURAL GAS													
			Orifice Size, In. / mm													
	psig	bar	1/4 x 3/8 / 6.4 x 9.5		3/8 / 9.5		1/2 / 13		3/4 / 19		7/8 / 22		1 / 25		1-3/16 / 30	
			SCFH	Nm ³ /h	SCFH	Nm ³ /h	SCFH	Nm ³ /h	SCFH	Nm ³ /h	SCFH	Nm ³ /h	SCFH	Nm ³ /h	SCFH	Nm ³ /h
1 to 3.25 psig / 69 mbar to 0.22 bar 2 psig / 0.14 bar ±1% psia / bar T13593T0012 Light Blue	5	0.34	1020	27.3	2100	56.4	3640	97.5	7440	199	8650	232	11,140	299	13,560	363
	10	0.69	1550	41.5	3340	89.5	5810	156	12,040	323	14,410	386	18,460	495	22,570	605
	15	1.0	1920	51.4	4360	117	7580	203	15,990	429	18,950	508	25,050	671	30,760	824
	20	1.4	2240	60.0	5150	138	8960	240	19,250	516	24,110	646	30,380	814	37,410	1003
	25	1.7	2570	68.9	5890	158	10,250	275	22,030	590	27,110	727	36,370	975	45,330	1215
	30	2.1	2890	77.4	6640	178	11,540	309	24,800	665	31,110	834	40,950	1097	51,040	1368
	40	2.8	3530	94.6	8120	218	14,120	378	30,350	813	38,100	1021	50,100	1343	62,450	1674
	50	3.4	4180	112	9600	257	16,700	448	35,890	962	44,100	1182	59,260	1588	73,870	1980
	60	4.1	4820	129	11,090	297	19,280	517	41,440	1111	51,090	1369	68,420	1834	85,290	2286
	80	5.5	6110	164	14,050	377	24,440	655	52,540	1408	65,080	1744	86,740	2325	108,120	2898
	100	6.9	7400	198	17,020	456	29,600	793	63,630	1705	79,060	2119	105,060	2816		
	125	8.6	9020	242	20,730	556	36,050	966	77,500	2077	96,050	2574				
150	10.3	10,630	285	24,440	655	42,500	1139	91,360	2448							
175	12.1	12,240	328	28,150	754	48,950	1312									
2.75 to 6 psig / 0.19 to 0.41 bar 5 psig / 0.34 bar ±1% psia / bar T13671T0012 Orange	10	0.69	1390	37.2	2910	78.0	5050	135	10,350	277	12,700	340	15,600	418	19,030	510
	15	1.0	1870	50.1	4190	112	7280	195	15,150	406	17,950	481	23,310	625	28,530	765
	20	1.4	2240	60.0	5090	136	8850	237	18,640	500	22,970	616	29,180	782	35,820	960
	25	1.7	2570	68.9	5890	158	10,250	275	22,030	590	27,110	727	34,550	926	42,530	1140
	30	2.1	2890	77.4	6640	178	11,540	309	24,800	665	31,110	834	40,950	1097	51,040	1368
	40	2.8	3530	94.6	8120	218	14,120	378	30,350	813	38,100	1021	50,100	1343	62,450	1674
	50	3.4	4180	112	9600	257	16,700	448	35,890	962	44,100	1182	59,260	1588	73,870	1980
	60	4.1	4820	129	11,090	297	19,280	517	41,440	1111	51,090	1369	68,420	1834	85,290	2286
	80	5.5	6110	164	14,050	377	24,440	655	52,540	1408	65,080	1744	86,740	2325	108,120	2898
	100	6.9	7400	198	17,020	456	29,600	793	63,630	1705	79,060	2119	105,060	2816		
	125	8.6	9020	242	20,730	556	36,050	966	77,500	2077	96,050	2574				
	150	10.3	10,630	285	24,440	655	42,500	1139	91,360	2448						
175	12.1	12,240	328	28,150	754	48,950	1312									
5 to 16 psig / 0.34 to 1.1 bar 10 psig / 0.69 bar ±1% psia / bar T13600T0012 Red	15	1.0	1580	42.3	3280	87.9	5690	152	11,640	312	12,640	339	17,470	468	21,280	570
	20	1.4	2130	57.1	4720	126	8210	220	17,000	456	20,380	546	25,940	695	31,690	849
	25	1.7	2540	68.1	5710	153	9930	266	20,790	557	24,570	658	32,220	863	39,480	1058
	30	2.1	2890	77.4	6640	178	11,540	309	24,150	647	29,540	792	37,900	1016	46,550	1248
	40	2.8	3530	94.6	8120	218	14,120	378	30,350	813	38,100	1021	50,100	1343	62,450	1674
	50	3.4	4180	112	9600	257	16,700	448	35,890	962	44,100	1182	59,260	1588	73,870	1980
	60	4.1	4820	129	11,090	297	19,280	517	41,440	1111	51,090	1369	68,420	1834	85,290	2286
	80	5.5	6110	164	14,050	377	24,440	655	52,540	1408	65,080	1744	86,740	2325	108,120	2898
	100	6.9	7400	198	17,020	456	29,600	793	63,630	1705	79,060	2119	105,060	2816		
	125	8.6	9020	242	20,730	556	36,050	966	77,500	2077	96,050	2574				
	150	10.3	10,630	285	24,440	655	42,500	1139	91,360	2448						
	175	12.1	12,240	328	28,150	754	48,950	1312								
5 to 16 psig / 0.34 to 1.1 bar 15 psig / 1.0 ba ±1% psia / bar T13600T0012 Red	20	1.4	1750	46.9	3620	97.0	6290	169	12,830	344	15,830	424	19,190	514	23,360	626
	25	1.7	2360	63.2	5220	140	9070	243	18,700	501	22,040	591	28,360	760	34,610	928
	30	2.1	2820	75.6	6290	169	10,940	293	22,790	611	27,870	747	35,050	939	42,890	1149
	40	2.8	3530	94.6	8120	218	14,120	378	29,650	795	36,530	979	46,610	1249	57,270	1535
	50	3.4	4180	112	9600	257	16,700	448	35,890	962	44,100	1182	57,080	1530	70,350	1885
	60	4.1	4820	129	11,090	297	19,280	517	41,440	1111	51,090	1369	68,420	1834	85,290	2286
	80	5.5	6110	164	14,050	377	24,440	655	52,540	1408	65,080	1744	86,740	2325	108,120	2898
	100	6.9	7400	198	17,020	456	29,600	793	63,630	1705	79,060	2119	105,060	2816		
	125	8.6	9020	242	20,730	556	36,050	966	77,500	2077	96,050	2574				
	150	10.3	10,630	285	24,440	655	42,500	1139	91,360	2448						
	175	12.1	12,240	328	28,150	754	48,950	1312								
	14 to 35 psig / 0.97 to 2.4 bar 20 psig / 1.4 bar ±1% psia / bar 19B0432X012 Zinc	25	1.7	1920	51.4	3930	105	6840	183	13,930	373	14,960	401	20,800	557	25,310
30		2.1	2580	69.1	5680	152	9870	265	20,280	544	24,090	646	30,630	821	37,340	
40		2.8	3480	93.3	7830	210	13,610	365	28,440	762	34,480	924	43,980	1179	53,880	
50		3.4	4180	112	9600	257	16,700	448	35,140	942	41,940	1124	55,310	1482	67,980	
60		4.1	4820	129	11,090	297	19,280	517	41,440	1111	51,090	1369	65,780	1763	81,060	
80		5.5	6110	164	14,050	377	24,440	655	52,540	1408	65,080	1744	86,740	2325	108,120	
100		6.9	7400	198	17,020	456	29,600	793	63,630	1705	79,060	2119	105,060	2816		
125		8.6	9020	242	20,730	556	36,050	966	77,500	2077	96,050	2574				
150		10.3	10,630	285	24,440	655	42,500	1139	91,360	2448						
175		12.1	12,240	328	28,150	754	48,950	1312								

Blank areas indicate where maximum operating inlet pressure for a given orifice size is exceeded.
1. Downstream piping may affect actual capacity. It may be necessary to use enlarged downstream piping to obtain published capacities.



299H Series

Table 5. Types 299H and 299HR Flow Capacities⁽¹⁾ for 1-1/2 NPT and NPS 2 / DN 50 External/Dual Registration (continued)

OUTLET PRESSURE RANGE SETTING, ACCURACY, SPRING PART NUMBER AND COLOR	INLET PRESSURE		CAPACITIES IN SCFH / Nm ³ /h OF 0.6 SPECIFIC GRAVITY NATURAL GAS													
			Orifice Size, In. / mm													
			1/4 x 3/8 / 6.4 x 9.5		3/8 / 9.5		1/2 / 13		3/4 / 19		7/8 / 22		1 / 25		1-3/16 / 30	
	psig	bar	SCFH	Nm ³ /h	SCFH	Nm ³ /h	SCFH	Nm ³ /h	SCFH	Nm ³ /h	SCFH	Nm ³ /h	SCFH	Nm ³ /h	SCFH	Nm ³ /h
14 to 35 psig / 0.97 to 2.4 bar 25 psig / 1.7 bar ±1% psia / bar 19B0432X012 Zinc	30	2.1	2070	55.5	4230	113	7360	197	14,980	401	18,330	491	22,310	598	27,140	727
	40	2.8	3320	89.0	7350	197	12,780	343	26,420	708	32,120	861	40,220	1078	49,120	1316
	50	3.4	4140	111	9340	250	16,250	436	34,040	912	40,400	1083	52,830	1416	64,770	1736
	60	4.1	4820	129	11,090	297	19,280	517	40,630	1089	48,920	1311	64,010	1715	78,690	2109
	80	5.5	6110	164	14,050	377	24,440	655	52,540	1408	65,080	1744	86,740	2325	108,120	2898
14 to 35 psig / 0.97 to 2.4 bar 30 psig / 2.1 bar ±1% psia / bar 19B0432X012 Zinc	40	2.8	2980	79.9	6520	175	11,330	304	23,190	621	27,330	732	34,790	932	42,370	1136
	50	3.4	4020	108	8950	240	15,560	417	32,300	866	37,410	1003	49,460	1326	60,480	1621
	60	4.1	4800	129	10,850	291	18,870	506	39,600	1061	46,980	1259	61,630	1652	75,590	2026
	80	5.5	6110	164	14,050	377	24,440	655	52,540	1408	65,080	1744	83,170	2229	102,470	2746
	100	6.9	7400	198	17,020	456	29,600	793	63,630	1705	79,060	2119	105,060	2816		
14 to 35 psig / 0.97 to 2.4 bar 35 psig / 2.4 bar ±1% psia / bar 19B0432X012 Zinc	40	2.8	2350	63.0	4790	128	8330	223	16,920	453	20,530	550	25,150	674	30,580	820
	50	3.4	3770	101	8300	222	14,430	387	29,690	796	34,220	917	44,890	1203	54,750	1467
	60	4.1	4700	126	10,510	282	18,270	490	38,050	1020	44,960	1205	58,520	1568	71,620	1919
	80	5.5	6110	164	14,050	377	24,440	655	51,600	1383	62,470	1674	81,400	2182	100,090	2682
	100	6.9	7400	198	17,020	456	29,600	793	63,630	1705	79,060	2119	105,060	2816		
30 to 60 psig / 2.1 to 4.1 bar 40 psig / 2.8 bar ±1% psia / bar 19B0432X022 Green	50	3.4	3340	89.5	7290	195	12,670	340	25,840	693	30,500	817	38,590	1034	46,950	1258
	60	4.1	4500	121	9970	267	17,340	465	35,820	960	42,700	1144	54,480	1460	66,530	1783
	80	5.5	6100	163	13,840	371	24,070	645	50,670	1358	61,300	1643	79,160	2121	97,160	2604
	100	6.9	7400	198	17,020	456	29,600	793	63,630	1705	77,250	2070	100,560	2695		
	125	8.6	9020	242	20,730	556	36,050	966	77,500	2077	95,700	2565				
30 to 60 psig / 2.1 to 4.1 bar 50 psig / 3.4 bar ±1% psia / bar 19B0432X022 Green	60	4.1	3680	98.6	7990	214	13,900	373	28,290	758	33,300	892	42,110	1129	51,210	1372
	80	5.5	5900	158	13,170	353	22,900	614	47,570	1275	57,000	1528	72,950	1955	89,220	2391
	100	6.9	7400	198	16,830	451	29,260	784	61,700	1654	74,800	2005	96,630	2590		
	125	8.6	9020	242	20,730	556	36,050	966	77,500	2077	94,400	2530				
	150	10.3	10,630	285	24,440	655	42,500	1139	91,360	2448						
30 to 60 psig / 2.1 to 4.1 bar 60 psig / 4.1 bar ±1% psia / bar 19B0432X022 Green	80	5.5	5380	144	11,810	317	20,540	550	42,160	1130	50,000	1340	63,540	1703	77,440	2075
	100	6.9	7260	195	16,270	436	28,290	758	59,000	1581	70,900	1900	90,970	2438		
	125	8.6	9020	242	20,730	556	35,860	961	75,900	2034	92,300	2474				
	150	10.3	10,630	285	24,440	655	42,500	1139	91,360	2448						
	175	12.1	12,240	328	28,150	754	48,950	1312								

- Blank areas indicate where maximum operating inlet pressure for a given orifice size is exceeded.

1. Downstream piping may affect actual capacity. It may be necessary to use enlarged downstream piping to obtain published capacities.



299H Series

Table 6. Types 299H and 299HR Flow Capacities⁽¹⁾ for 1-1/2 NPT Internal Registration

OUTLET PRESSURE RANGE SETTING, ACCURACY, SPRING PART NUMBER AND COLOR	INLET PRESSURE		CAPACITIES IN SCFH / Nm ³ /h OF 0.6 SPECIFIC GRAVITY NATURAL GAS											
			Orifice Size, In. / mm											
	psig	bar	1/4 x 3/8 / 6.4 x 9.5		3/8 / 9.5		1/2 / 13		3/4 / 19		1 / 25		1-3/16 / 30	
			SCFH	Nm ³ /h	SCFH	Nm ³ /h	SCFH	Nm ³ /h	SCFH	Nm ³ /h	SCFH	Nm ³ /h	SCFH	Nm ³ /h
3.5 to 6 in. w.c. / 9 to 15 mbar 3.5 in. w.c. / 9 mbar -1 to 2 in. w.c. / -2 to 5 mbar T13707T0012 Black	2	0.14	760	20.4	1560	41.8	2700	72.4	4050	109	4340	116	4540	122
	5	0.34	1200	32.2	2600	69.7	4500	121	8490	228	10,690	286	7290	195
	10	0.69	1700	45.6	3800	102	6500	174	7140	191	8570	230	10,570	283
	15	1.0	2000	53.6	4600	123	8000	214	7120	191	10,860	291	9020	242
	20	1.4	2350	63.0	5300	142	9250	248	7060	189	11,250	302	9810	263
	25	1.7	2700	72.4	6000	161	10,010	268	7100	190	11,170	299	9760	262
	30	2.1	3040	81.5	6740	181	10,330	277	8030	215	11,660	312	9700	260
	40	2.8	3700	99.2	8200	220	11,640	312	9610	258	10,790	289	11,150	299
	50	3.4	4400	118	9700	260	11,650	312	10,530	282	9460	254	10,100	271
	60	4.1	5100	137	11,200	300	11,380	305	11,590	311	9010	241	10,200	273
	80	5.5	4700	126	4680	125	4510	121	15,210	408	6250	168	8900	239
	100	6.9	4300	115	3040	81.5	3990	107	14,510	389	7700	206		
	125	8.6	4300	115	3200	85.8	4390	118	8640	232				
	150	10.3	4320	116	3200	85.8	4810	129	2650	71.0				
	175	12.1	5600	150	5050	135	7300	196						
5 to 9 in. w.c. / 12 to 22 mbar 7 in. w.c. / 17 mbar -1 to 2 in. w.c. / -2 to 5mbar T13589T0012 Yellow	2	0.14	750	20.1	1520	40.7	2650	71.0	5380	144	5610	150	5790	155
	5	0.34	1300	34.8	2600	69.7	4250	114	7110	191	7600	204	6620	177
	10	0.69	1600	42.9	3800	102	6500	174	8150	218	8210	220	10,320	277
	15	1.0	2000	53.6	4400	118	8000	214	6180	166	10,770	289	9040	242
	20	1.4	2300	61.6	5100	137	9500	255	6520	175	11,510	308	9510	255
	25	1.7	2600	69.7	5800	155	10,660	286	6190	166	10,920	293	9850	264
	30	2.1	2970	79.6	6600	177	10,410	279	7420	199	10,850	291	10,080	270
	40	2.8	3700	99.2	8200	220	10,170	273	12,030	322	10,310	276	10,170	273
	50	3.4	4400	118	9700	260	11,170	299	12,160	326	10,430	280	10,000	268
	60	4.1	5100	137	11,200	300	11,710	314	10,620	285	8230	221	10,200	273
	80	5.5	4850	130	4700	126	4570	122	3610	96.7	8000	214	8500	228
	100	6.9	4600	123	2800	75.0	3790	102	3380	90.6	6400	172		
	125	8.6	4600	123	3200	85.8	4190	112	3440	92.2				
	150	10.3	4600	123	3640	97.5	4590	123	2400	64.3				
	175	12.1	5400	145	5050	135	7300	196						
7 to 20 in. w.c. / 17 to 50 mbar 14 in. w.c. / 35 mbar ±2 in. w.c. / ±5 mbar 1N3112X0012 Unpainted	2	0.14	700	18.8	1430	38.3	2480	66.5	5040	135	6900	185	7050	189
	5	0.34	1100	29.5	2200	59.0	4000	107	7180	192	7280	195	8860	237
	10	0.69	1700	45.6	3600	96.5	6500	174	8310	223	9330	250	10,320	277
	15	1.0	1900	50.9	4600	123	8000	214	7000	188	11,940	320	9530	255
	20	1.4	2150	57.6	5300	142	8500	228	7410	199	11,850	318	11,060	296
	25	1.7	2400	64.3	6000	161	9000	241	6900	185	11,330	304	11,080	297
	30	2.1	2740	73.4	6740	181	10,000	268	6500	174	11,270	302	10,780	289
	40	2.8	3400	91.1	8200	220	10,900	292	9220	247	10,820	290	11,220	301
	50	3.4	4250	114	9700	260	10,210	274	12,580	337	10,820	290	10,450	280
	60	4.1	5100	137	11,000	295	9650	259	11,750	315	8840	237	11,100	297
	80	5.5	5250	141	5210	140	4060	109	4970	133	8550	229	9400	252
	100	6.9	5400	145	4580	123	4410	118	4970	133	6780	182		
	125	8.6	5400	145	4400	118	5290	142	4330	116				
	150	10.3	5900	158	5020	135	6170	165	3130	83.9				
	175	12.1	555	149	5200	139	6500	174						
16 to 40 in. w.c. / 40 to 99 mbar 28 in. w.c. / 70 mbar ±4 in. w.c. / ±10 mbar 1B413727222 Purple	5	0.34	1200	32.2	2400	64.3	4000	107	6010	161	9210	247	9070	243
	10	0.69	1600	42.9	3700	99.2	6500	174	8130	218	10,300	276	10,650	285
	15	1.0	2000	53.6	4400	118	8000	214	10,340	277	13,020	349	12,890	345
	20	1.4	2300	61.6	5100	137	9250	248	11,980	321	14,790	396	13,170	353
	25	1.7	2600	69.7	5800	155	10,500	281	12,390	332	14,570	390	14,180	380
	30	2.1	2800	75.0	6600	177	11,840	317	12,500	335	14,050	377	13,770	369
	40	2.8	3200	85.8	8200	220	14,060	377	13,350	358	13,290	356	14,110	378
	50	3.4	4100	110	9750	261	14,010	375	14,530	389	12,860	345	12,050	323
	60	4.1	5000	134	11,100	297	14,040	376	13,440	360	13,020	349	10,950	293
	80	5.5	6300	169	5910	158	6140	165	9950	267	8500	228	10,200	273
	100	6.9	7600	204	5220	140	5420	145	7780	209	6500	174		
	125	8.6	9200	247	5690	152	6010	161	8220	220				
	150	10.3	10,700	287	7380	198	5970	160	4900	131				
	175	12.1	5510	148	5100	137	7250	194						

Blank areas indicate where maximum operating inlet pressure for a given orifice size is exceeded.
1. Downstream piping may affect actual capacity. It may be necessary to use enlarged downstream piping to obtain published capacities.



299H Series

Table 6. Types 299H and 299HR Flow Capacities⁽¹⁾ for 1-1/2 NPT Internal Registration (continued)

OUTLET PRESSURE RANGE SETTING, ACCURACY, SPRING PART NUMBER AND COLOR	INLET PRESSURE		CAPACITIES IN SCFH / Nm ³ /h OF 0.6 SPECIFIC GRAVITY NATURAL GAS												
			Orifice Size, In. / mm												
			1/4 x 3/8 / 6.4 x 9.5		3/8 / 9.5		1/2 / 13		3/4 / 19		1 / 25		1-3/16 / 30		
	psig	bar	SCFH	Nm ³ /h	SCFH	Nm ³ /h	SCFH	Nm ³ /h	SCFH	Nm ³ /h	SCFH	Nm ³ /h	SCFH	Nm ³ /h	
1 to 3.25 psig / 69 mbar to 0.22 bar 2 psig / 0.14 bar ±1% psia / bar T13593T0012 Light Blue	5	0.34	1020	27.3	2100	56.4	3640	97.5	7020	188	10,790	289	10,820	290	
	10	0.69	1550	41.5	3340	89.5	5840	157	8990	241	12,180	326	11,180	300	
	15	1.0	1920	51.4	4360	117	7580	203	11,260	302	13,580	364	11,960	321	
	20	1.4	2240	60.0	5150	138	8960	240	12,950	347	13,630	365	12,750	342	
	25	1.7	2570	68.9	5890	158	10,250	275	13,090	351	13,890	372	13,370	358	
	30	2.1	2890	77.4	6640	178	11,540	309	14,830	397	13,740	368	14,000	375	
	40	2.8	3530	94.6	8120	218	14,120	378	13,500	362	13,470	361	15,250	409	
	50	3.4	4180	112	9600	257	15,010	402	13,780	369	13,970	374	12,500	335	
	60	4.1	4820	129	10,890	292	15,740	422	14,050	377	14,080	377	12,300	330	
	80	5.5	6110	164	9000	241	12,230	328	11,100	297	12,750	342	10,500	281	
	100	6.9	7400	198	5200	139	5200	139	5200	139	6400	172			
	125	8.6	8170	219	5040	135	5200	139	5200	139					
	150	10.3	8450	226	5870	157	5200	139	5600	150					
	175	12.1	7750	208	5250	141	5730	154							
2.75 to 6 psig / 0.19 to 0.41 bar 5 psig / 0.34 bar ±1% psia / bar T13671T0012 Orange	10	0.69	1390	37.2	2910	78.0	5050	135	8470	227	12,010	322	12,190	327	
	15	1.0	1870	50.1	4190	112	7280	195	11,290	303	14,300	383	12,400	332	
	20	1.4	2240	60.0	5090	136	8850	237	12,590	337	13,820	370	13,260	355	
	25	1.7	2570	68.9	5890	158	10,250	275	13,210	354	14,500	389	14,310	384	
	30	2.1	2890	77.4	6640	178	11,540	309	13,820	370	15,290	410	15,370	412	
	40	2.8	3530	94.6	8120	218	14,120	378	15,060	404	15,650	419	16,630	446	
	50	3.4	4180	112	9600	257	16,700	448	15,400	413	16,010	429	14,000	375	
	60	4.1	4820	129	11,090	297	16,290	437	15,750	422	16,370	439	13,250	355	
	80	5.5	6110	164	14,050	377	14,000	375	13,620	365	14,000	375	14,000	375	
	100	6.9	7400	198	17,020	456	9020	242	9610	258	14,000	375			
	125	8.6	9020	242	7690	206	7690	206	7890	211					
	150	10.3	10,630	285	6330	170	6360	170	5500	147					
	175	12.1	6800	182	6050	162	8200	220							
	5 to 16 psig / 0.34 to 1.1 bar 10 psig / 0.69 bar ±1% psia / bar T13600T0012 Red	15	1.0	1580	42.3	3280	87.9	5690	152	9930	266	13,230	355	13,570	364
20		1.4	2130	57.1	4720	126	8210	220	11,990	321	14,130	379	14,100	378	
25		1.7	2540	68.1	5740	154	9940	266	13,400	359	15,990	429	15,870	425	
30		2.1	2890	77.4	6580	176	11,440	307	14,810	397	17,850	478	17,640	473	
40		2.8	3530	94.6	8120	218	14,120	378	17,640	473	18,630	499	18,920	507	
50		3.4	4180	112	9600	257	16,700	448	18,110	485	19,400	520	16,400	440	
60		4.1	4820	129	11,090	297	17,200	461	18,580	498	20,170	541	16,600	445	
80		5.5	6110	164	14,050	377	16,950	454	17,810	477	15,750	422	17,600	472	
100		6.9	7400	198	17,020	456	15,350	411	15,900	426	15,950	427			
125		8.6	9020	242	20,730	556	16,740	449	16,270	436					
150		10.3	6790	182	6790	182	6830	183	5800	155					
175		12.1	6200	166	5600	150	5700	153							
5 to 16 psig / 0.34 to 1.1 bar 15 psig / 1.0 bar ±1% psia / bar T13600T0012 Red		20	1.4	1750	46.9	3620	97.0	6290	169	11,380	305	114,450	3067	14,980	401
		25	1.7	2360	63.2	5220	140	9070	243	13,590	364	17,440	467	17,430	467
	30	2.1	2820	75.6	6290	169	10,940	293	15,810	424	20,430	548	19,910	534	
	40	2.8	3540	94.9	8070	216	14,020	376	20,230	542	21,610	579	21,220	569	
	50	3.4	4180	112	9600	257	16,700	448	20,820	558	22,800	611	20,500	549	
	60	4.1	4820	129	11,090	297	18,110	485	21,410	574	23,890	640	21,600	579	
	80	5.5	6110	164	14,050	377	19,910	534	22,000	590	19,500	523	19,900	533	
	100	6.9	7400	198	17,020	456	21,710	582	22,600	606	22,200	595			
	125	8.6	9020	242	20,730	556	23,960	642	23,190	621					
	150	10.3	10,630	285	24,440	655	26,210	702	21,200	568					
	175	12.1	7400	198	6750	181	7100	190							
	14 to 35 psig / 0.97 to 2.4 bar 20 psig / 1.4 bar ±1% psia / bar 19B0432X012 Zinc	25	1.7	1920	51.4	3930	105	6840	183	12,840	344	15,670	420	16,320	437
		30	2.1	2580	69.1	5690	152	9870	265	15,200	407	20,740	556	20,760	556
		40	2.8	3480	93.3	7830	210	13,610	365	22,820	612	24,600	659	23,510	630
50		3.4	4180	112	9550	256	16,610	445	20,950	561	23,620	633	22,200	595	
60		4.1	4820	129	11,090	297	18,080	485	23,330	625	26,120	700	25,000	670	
80		5.5	6110	164	14,050	377	20,980	562	25,120	673	24,500	657	24,900	667	
100		6.9	7400	198	17,020	456	23,680	635	26,930	722	26,200	702			
125		8.6	9020	242	20,730	556	26,980	723	28,020	751					
150		10.3	10,630	285	24,440	655	30,280	812	21,600	579					
175		12.1	7500	201	8200	220	8600	230							

- Blank areas indicate where maximum operating inlet pressure for a given orifice size is exceeded.

1. Downstream piping may affect actual capacity. It may be necessary to use enlarged downstream piping to obtain published capacities.



299H Series

Table 6. Types 299H and 299HR Flow Capacities⁽¹⁾ for 1-1/2 NPT Internal Registration (continued)

OUTLET PRESSURE RANGE SETTING, ACCURACY, SPRING PART NUMBER AND COLOR	INLET PRESSURE		CAPACITIES IN SCFH / Nm ³ /h OF 0.6 SPECIFIC GRAVITY NATURAL GAS											
			Orifice Size, In. / mm											
	psig	bar	1/4 x 3/8 / 6.4 x 9.5		3/8 / 9.5		1/2 / 13		3/4 / 19		1 / 25		1-3/16 / 30	
			SCFH	Nm ³ /h	SCFH	Nm ³ /h	SCFH	Nm ³ /h	SCFH	Nm ³ /h	SCFH	Nm ³ /h	SCFH	Nm ³ /h
14 to 35 psig / 0.97 to 2.4 bar 25 psig / 1.7 bar ±1% psia / bar 19B0432X012 Zinc	30	2.1	2070	55.5	4230	113	7360	197	14,300	383	16,880	452	17,700	474
	40	2.8	3320	89.0	7350	197	12,780	343	16,810	451	24,040	644	24,090	646
	50	3.4	4140	111	9340	250	16,250	436	21,090	565	24,430	655	23,500	630
	60	4.1	4830	129	11,030	296	18,050	484	25,240	676	28,260	757	27,400	734
	80	5.5	6110	164	14,050	377	22,050	591	28,250	757	30,200	809	28,500	764
	100	6.9	7400	198	17,020	456	25,650	687	31,260	838	27,000	724		
	125	8.6	9020	242	20,730	556	30,000	804	32,840	880				
14 to 35 psig / 0.97 to 2.4 bar 30 psig / 2.1 bar ±1% psia / bar 19B0432X012 Zinc	40	2.8	2980	79.9	6520	175	11,330	304	15,750	422	18,100	485	19,080	511
	50	3.4	4020	108	8950	240	15,560	417	21,220	569	25,240	676	22,500	603
	60	4.1	4800	129	10,850	291	18,020	483	27,150	728	30,390	814	28,000	750
	80	5.5	6110	164	14,050	377	23,130	620	31,370	841	30,500	817	32,300	866
	100	6.9	7400	198	17,020	456	27,630	740	35,690	956	32,500	871		
	125	8.6	9020	242	20,730	556	33,030	885	37,670	1010				
	150	10.3	10,630	285	24,440	655	38,430	1030	32,000	858				
14 to 35 psig / 0.97 to 2.4 bar 35 psig / 2.4 bar ±1% psia / bar 19B0432X012 Zinc	40	2.8	2350	63.0	4790	128	8330	223	13,640	366	19,570	524	20,850	559
	50	3.4	3770	101	8300	222	14,430	387	21,350	572	26,060	698	22,000	590
	60	4.1	4700	126	10,510	282	18,270	490	29,060	779	32,530	872	29,000	777
	80	5.5	6120	164	14,000	375	24,350	653	34,490	924	34,500	925	33,600	900
	100	6.9	7400	198	17,020	456	29,600	793	39,920	1070	38,200	1024		
	125	8.6	9020	242	20,730	556	36,050	966	42,500	1139				
	150	10.3	10,630	285	24,440	655	42,500	1139	32,100	860				
30 to 60 psig / 2.1 to 4.1 bar 40 psig / 2.8 bar ±1% psia / bar 19B0432X022 Green	50	3.4	2400	64.3	6000	161	10,000	268	14,000	375	20,000	536	20,000	536
	60	4.1	3470	93.0	8000	214	13,670	366	22,000	590	26,000	697	22,667	607
	80	5.5	5600	150	12,000	322	21,000	563	38,000	1018	30,000	804	28,000	750
	100	6.9	6400	172	14,500	389	27,000	724	38,000	1018	34,000	911		
	125	8.6	7600	204	19,500	523	33,000	884	38,000	1018				
	150	10.3	9500	255	22,750	610	37,000	992	42,000	1126				
	175	12.1	11,400	306	26,000	697	41,000	1099						
30 to 60 psig / 2.1 to 4.1 bar 50 psig / 3.4 bar ±1% psia / bar 19B0432X022 Green	60	4.1	3000	80.4	6500	174	9500	255	16,250	436	22,500	603	25,000	670
	80	5.5	5250	141	10,750	288	17,750	476	28,750	771	31,250	838	32,500	871
	100	6.9	6750	181	15,000	402	26,000	697	41,250	1106	40,000	1072		
	125	8.6	8250	221	17,500	469	32,500	871	43,750	1173				
	150	10.3	9500	255	21,750	583	37,750	1012	46,250	1240				
	175	12.1	10,750	288	26,000	697	43,000	1152						
	30 to 60 psig / 2.1 to 4.1 bar 60 psig / 4.1 bar ±1% psia / bar 19B0432X022 Green	80	5.5	2750	73.7	7200	193	13,000	348	18,750	503	27,500	737	32,500
100		6.9	2750	73.7	10,600	284	15,500	415	25,000	670	40,000	1072		
125		8.6	3250	87.1	3000	80.4	22,000	590	46,250	1240				
150		10.3	3130	83.9	2900	77.7	18,000	482	11,250	302				
175	12.1	3000	80.4	2800	75.0	14,000	375							

- Blank areas indicate where maximum operating inlet pressure for a given orifice size is exceeded.
1. Downstream piping may affect actual capacity. It may be necessary to use enlarged downstream piping to obtain published capacities.



299H Series

Table 7. Types 299H and 299HR Flow Capacities⁽¹⁾ for NPS 2 / DN 50 Internal Registration

OUTLET PRESSURE RANGE SETTING, ACCURACY, SPRING PART NUMBER AND COLOR	INLET PRESSURE		CAPACITIES IN SCFH / Nm ³ /h OF 0.6 SPECIFIC GRAVITY NATURAL GAS											
			Orifice Size, In. / mm											
			1/4 x 3/8 / 6.4 x 9.5		3/8 / 9.5		1/2 / 13		3/4 / 19		1 / 25		1-3/16 / 30	
	psig	bar	SCFH	Nm ³ /h	SCFH	Nm ³ /h	SCFH	Nm ³ /h	SCFH	Nm ³ /h	SCFH	Nm ³ /h	SCFH	Nm ³ /h
3.5 to 6 in. w.c. / 9 to 15 mbar 3.5 in. w.c. / 9 mbar -1 to 2 in. w.c. / -2 to 5 mbar T13707T0012 Black	2	0.14	760	20.4	1560	41.8	2700	72.4	4050	109	5740	154	6350	170
	5	0.34	1200	32.2	2600	69.7	4500	121	8600	230	11,500	308	12,000	322
	10	0.69	1700	45.6	3800	102	6500	174	9500	255	14,750	395	17,000	456
	15	1.0	2000	53.6	4600	123	8000	214	10,600	284	18,000	482	15,500	415
	20	1.4	2350	63.0	5300	142	9250	248	11,400	306	19,700	528	16,000	429
	25	1.7	2700	72.4	6000	161	10,500	281	12,200	327	20,400	547	17,300	464
	30	2.1	3030	81.2	6730	180	11,500	308	14,630	392	21,100	565	18,600	498
	40	2.8	3700	99.2	8200	220	13,500	362	19,500	523	20,400	547	21,800	584
	50	3.4	4400	118	9700	260	17,000	456	20,000	536	19,700	528	25,000	670
	60	4.1	5100	137	11,200	300	20,500	549	20,500	549	14,833	398	12,500	335
	80	5.5	4700	126	7500	201	12,750	342	19,600	525	5100	137	12,000	322
	100	6.9	4300	115	3800	102	5000	134	18,700	501	3500	93.8		
	125	8.6	4300	115	4000	107	5500	147	11,150	299				
	150	10.3	4300	115	4000	107	6000	161	3600	96.5				
	175	12.1	4300	115	4000	107	6500	174						
5 to 9 in. w.c. / 12 to 22 mbar 7 in. w.c. / 17 mbar -1 to 2 in. w.c. / -2 to 5 mbar T13589T0012 Yellow	2	0.14	750	20.1	1520	40.7	2650	71.0	5380	144	6260	168	6680	179
	5	0.34	1300	34.8	2600	69.7	4250	114	8500	228	10,500	281	10,000	268
	10	0.69	1600	42.9	3800	102	6500	174	12,500	335	14,350	385	17,000	456
	15	1.0	2000	53.6	4400	118	8000	214	10,500	281	18,200	488	16,000	429
	20	1.4	2300	61.6	5100	137	9500	255	11,500	308	20,600	552	16,000	429
	25	1.7	2600	69.7	5800	155	11,000	295	12,500	335	20,500	549	17,750	476
	30	2.1	2970	79.6	6600	177	11,170	299	16,830	451	20,400	547	19,500	523
	40	2.8	3700	99.2	8200	220	11,500	308	25,500	683	20,200	541	20,200	541
	50	3.4	4400	118	9700	260	15,750	422	22,500	603	20,000	536	20,900	560
	60	4.1	5100	137	11,200	300	20,000	536	19,500	523	14,800	397	12,500	335
	80	5.5	4850	130	7350	197	12,380	332	4500	121	4400	118	12,500	335
	100	6.9	4600	123	3500	93.8	4750	127	4500	121	2800	75.0		
	125	8.6	4600	123	4000	107	5250	141	4500	121				
	150	10.3	4600	123	4560	122	5750	154	4500	121				
	175	12.1	4600	123	5120	137	6500	174						
7 to 20 in. w.c. / 17 to 50 mbar 14 in. w.c. / 35 mbar ±2 in. w.c. / ±5 mbar 1N3112X0012 Unpainted	2	0.14	700	18.8	1430	38.3	2480	66.5	5040	135	7440	199	8460	227
	5	0.34	1100	29.5	2200	59.0	4000	107	8500	228	11,800	316	12,400	332
	10	0.69	1700	45.6	3600	96.5	6500	174	12,500	335	15,850	425	17,000	456
	15	1.0	1900	50.9	4600	123	8000	214	11,500	308	19,900	533	17,000	456
	20	1.4	2150	57.6	5300	142	8500	228	12,500	335	21,000	563	19,100	512
	25	1.7	2400	64.3	6000	161	9000	241	13,250	355	21,150	567	19,750	529
	30	2.1	2740	73.4	6740	181	10,000	268	14,000	375	21,300	571	20,400	547
	40	2.8	3400	91.1	8200	220	12,000	322	19,500	523	21,150	567	21,650	580
	50	3.4	4250	114	9700	260	13,500	362	25,000	670	21,000	563	22,900	614
	60	4.1	5100	137	11,200	300	15,000	402	22,050	591	16,330	438	14,100	378
	80	5.5	5250	141	8200	220	10,000	268	5620	151	7000	188	12,400	332
	100	6.9	5400	145	5200	139	5000	134	6000	161	8300	222		
	125	8.6	5400	145	5000	134	6000	161	6000	161				
	150	10.3	5900	158	5700	153	7000	188	6000	161				
	175	12.1	6400	172	6400	172	7000	188						
16 to 40 in. w.c. / 40 to 99 mbar 28 in. w.c. / 70 mbar ±4 in. w.c. / ±10 mbar 1B413727222 Purple	5	0.34	1200	32.2	2400	64.3	4000	107	7500	201	9500	255	11,400	306
	10	0.69	1600	42.9	3700	99.2	6500	174	11,750	315	14,850	398	16,850	452
	15	1.0	2000	53.6	4400	118	8000	214	16,000	429	20,200	541	22,300	598
	20	1.4	2300	61.6	5100	137	9250	248	19,000	509	24,500	657	21,800	584
	25	1.7	2600	69.7	5800	155	10,500	281	21,750	583	25,600	686	23,900	641
	30	2.1	2800	75.0	6600	177	11,830	317	24,500	657	25,230	676	24,130	647
	40	2.8	3200	85.8	8200	220	14,500	389	26,750	717	24,500	657	24,600	659
	50	3.4	4100	110	9750	261	16,500	442	29,000	777	24,000	643	26,000	697
	60	4.1	5000	134	11,300	303	18,500	496	24,170	648	23,500	630	27,200	729
	80	5.5	6300	169	9150	245	12,880	345	14,500	389	24,500	657	30,000	804
	100	6.9	7600	204	7000	188	7250	194	14,500	389	22,400	600		
	125	8.6	9200	247	7000	188	7380	198	14,500	389				
	150	10.3	10,700	287	9300	249	7500	201	15,500	415				
	175	12.1	12,200	327	11,600	311	15,250	409						

- Blank areas indicate where maximum operating inlet pressure for a given orifice size is exceeded.
1. Downstream piping may affect actual capacity. It may be necessary to use enlarged downstream piping to obtain published capacities.



299H Series

Table 7. Types 299H and 299HR Flow Capacities⁽¹⁾ for NPS 2 / DN 50 Internal Registration (continued)

OUTLET PRESSURE RANGE SETTING, ACCURACY, SPRING PART NUMBER AND COLOR	INLET PRESSURE		CAPACITIES IN SCFH / Nm ³ /h OF 0.6 SPECIFIC GRAVITY NATURAL GAS												
			Orifice Size, In. / mm												
	psig	bar	1/4 x 3/8 / 6.4 x 9.5		3/8 / 9.5		1/2 / 13		3/4 / 19		1 / 25		1-3/16 / 30		
			SCFH	Nm ³ /h	SCFH	Nm ³ /h	SCFH	Nm ³ /h	SCFH	Nm ³ /h	SCFH	Nm ³ /h	SCFH	Nm ³ /h	
1 to 3.25 psig / 69 bar to 0.22 bar 2 psig / 0.14 bar ± 1% psia / bar T13593T0012 Light Blue	5	0.34	1020	27.3	2100	56.4	3640	97.5	7440	199	10,980	294	13,800	370	
	10	0.69	1550	41.5	3340	89.5	5840	157	12,040	323	15,460	414	17,710	475	
	15	1.0	1920	51.4	4360	117	7580	203	15,990	429	20,900	560	20,670	554	
	20	1.4	2240	60.0	5150	138	8960	240	19,250	516	22,470	602	21,620	579	
	25	1.7	2670	71.5	5890	158	10,250	275	22,030	590	24,000	643	22,410	601	
	30	2.1	2890	77.4	6640	178	11,540	309	27,800	745	24,860	666	24,170	648	
	40	2.8	3530	94.6	8120	218	14,120	378	27,070	725	25,640	687	26,160	701	
	50	3.4	4180	112	9600	257	16,700	448	28,970	776	26,390	707	26,900	721	
	60	4.1	4820	129	11,090	297	19,280	517	25,770	691	26,000	697	29,000	777	
	80	5.5	6110	164	14,050	377	24,440	655	25,500	683	12,800	343	30,000	804	
	100	6.9	7400	198	17,020	456	29,840	800	14,260	382	28,300	758			
	125	8.6	8170	219	12,360	331	17,520	470	13,260	355					
	150	10.3	8450	226	13,750	369	18,580	498	17,000	456					
	175	12.1	12,400	332	7100	190	20,000	536							
	2.75 to 6 psig / 0.19 to 0.41 bar 5 psig / 0.34 bar ± 1% psig / bar T13671T0012 Orange	10	0.69	1390	37.2	2910	78.0	5050	135	10,350	277	13,200	354	16,070	431
15		1.0	1870	50.1	4190	112	7280	195	15,150	406	21,850	586	21,370	573	
20		1.4	2240	60.0	5090	136	8850	237	18,640	500	21,350	572	21,390	573	
25		1.7	2570	68.9	5890	158	10,250	275	21,260	570	24,540	658	22,740	609	
30		2.1	2890	77.4	6640	178	11,540	309	24,340	652	26,500	710	25,870	693	
40		2.8	3530	94.6	8120	218	14,120	378	27,670	742	28,300	758	28,930	775	
50		3.4	4180	112	9600	257	16,700	448	30,570	819	29,870	801	30,000	804	
60		4.1	4820	129	11,090	297	19,280	517	29,390	788	30,390	814	31,000	831	
80		5.5	6110	164	14,050	377	24,440	655	31,410	842	28,000	750	34,000	911	
100		6.9	7400	198	17,020	456	29,600	793	22,150	594	32,000	858			
125		8.6	9020	242	20,730	556	36,050	966	21,590	579					
150		10.3	10,630	285	17,170	460	26,560	712	17,000	456					
175		12.1	11,800	316	15,400	413	21,500	576							
5 to 16 psig / 0.34 to 1.1 bar 10 psig / 0.69 bar ± 1% psia / bar T13600T0012 Red		15	1.0	1580	42.3	3280	87.9	5690	152	11,640	312	15,420	413	18,340	492
		20	1.4	2130	57.1	4720	126	8210	220	17,000	456	19,500	523	21,000	563
	25	1.7	2540	68.1	5740	154	9940	266	20,790	557	25,440	682	23,290	624	
	30	2.1	2890	77.4	6580	176	11,440	307	24,150	647	29,250	784	28,700	769	
	40	2.8	3530	94.6	8120	218	14,120	378	28,660	768	32,780	879	33,540	899	
	50	3.4	4180	112	9600	257	16,700	448	33,230	891	35,680	956	33,100	887	
	60	4.1	4820	129	11,090	297	19,280	517	35,410	949	37,700	1010	33,100	887	
	80	5.5	6110	164	14,050	377	24,440	655	41,270	1106	38,000	1018	37,000	992	
	100	6.9	7400	198	17,020	456	29,600	793	35,310	946	35,000	938			
	125	8.6	9020	242	20,730	556	36,050	966	35,740	958					
	150	10.3	10,630	285	20,590	552	34,530	925	22,000	590					
	175	12.1	11,200	300	18,100	485	25,000	670							
	5 to 16 psig / 0.34 to 1.1 bar 15 psig / 10 bar ± 1% psia / bar T13600T0012 Red	20	1.4	1750	46.9	3620	97.0	6290	169	12,830	344	17,640	473	20,640	553
		25	1.7	2360	63.2	5220	140	9070	243	18,700	501	26,350	706	23,850	639
		30	2.1	2820	75.6	6290	169	10,940	293	22,790	611	31,990	857	31,540	845
40		2.8	3540	94.9	8070	216	14,020	376	29,650	795	37,270	999	38,150	1022	
50		3.4	4180	112	9600	257	16,700	448	35,890	962	41,490	1112	43,000	1152	
60		4.1	4820	129	11,090	297	19,280	517	41,440	1111	45,020	1207	39,000	1045	
80		5.5	6110	164	14,050	377	24,440	655	51,120	1370	49,000	1313	43,000	1152	
100		6.9	7400	198	17,020	456	29,600	793	48,470	1299	46,000	1233			
125		8.6	9020	242	20,730	556	36,050	966	49,780	1334					
150		10.3	10,630	285	24,440	655	42,500	1139	60,000	1608					
175		12.1	11,800	316	27,400	734	48,000	1286							
14 to 35 psig / 0.97 to 2.4 bar 20 psig / 14 bar ± 1% psia / bar 19B0432X012 Zinc		25	1.7	1920	51.4	3930	105	6840	183	13,930	373	20,800	557	21,940	588
		30	2.1	2580	69.1	5680	152	9870	265	20,280	544	30,630	821	32,630	874
		40	2.8	3480	93.3	7830	210	13,610	365	28,440	762	33,040	885	35,700	957
		50	3.4	4180	112	9550	256	16,610	445	35,140	942	41,800	1120	40,520	1086
	60	4.1	4820	129	11,090	297	19,280	517	41,440	1111	47,530	1274	40,520	1086	
	80	5.5	6110	164	14,050	377	24,440	655	51,240	1373	41,800	1120	41,000	1099	
	100	6.9	7400	198	17,020	456	29,600	793	52,260	1401	41,800	1120			
	125	8.6	9020	242	20,730	556	36,050	966	56,710	1520					
	150	10.3	10,630	285	24,440	655	42,500	1139	65,000	1742					
	175	12.1	11,600	311	26,300	705	47,000	1260							

Blank areas indicate where maximum operating inlet pressure for a given orifice size is exceeded.
1. Downstream piping may affect actual capacity. It may be necessary to use enlarged downstream piping to obtain published capacities.



299H Series

Table 7. Types 299H and 299HR Flow Capacities⁽¹⁾ for NPS 2 / DN 50 Internal Registration (continued)

OUTLET PRESSURE RANGE SETTING, ACCURACY, SPRING PART NUMBER AND COLOR	INLET PRESSURE		CAPACITIES IN SCFH / Nm ³ /h OF 0.6 SPECIFIC GRAVITY NATURAL GAS												
			Orifice Size, In. / mm												
			1/4 x 3/8 / 6.4 x 9.5		3/8 / 9.5		1/2 / 13		3/4 / 19		1 / 25		1-3/16 / 30		
	psig	bar	SCFH	Nm ³ /h	SCFH	Nm ³ /h	SCFH	Nm ³ /h	SCFH	Nm ³ /h	SCFH	Nm ³ /h	SCFH	Nm ³ /h	
14 to 35 psig / 0.97 to 2.4 bar 25 psig / 1.7 bar ±1% psia / bar 19B0432X012 Zinc	30	2.1	2070	55.5	4230	113	7360	197	14,980	401	22,310	598	23,270	624	
	40	2.8	3320	89.0	7350	197	12,780	343	23,420	628	40,220	1078	33,260	891	
	50	3.4	4140	111	9340	250	16,250	436	34,040	912	42,110	1129	50,000	1340	
	60	4.1	4830	129	11,030	296	19,190	514	40,630	1089	50,050	1341	54,000	1447	
	80	5.5	6110	164	14,050	377	24,440	655	51,360	1376	62,000	1662	60,000	1608	
	100	6.9	7400	198	17,020	456	29,600	793	56,050	1502	60,000	1608			
	125	8.6	9020	242	20,730	556	36,050	966	63,640	1706					
	150	10.3	10,630	285	24,440	655	42,500	1139	77,000	2064					
	175	12.1	11,000	295	26,500	710	46,000	1233							
	14 to 35 psig / 0.97 to 2.4 bar 30 psig / 2.1 bar ±1% psia / bar 19B0432X012 Zinc	40	2.8	2980	79.9	6520	175	11,330	304	23,190	621	24,580	659	30,810	826
50		3.4	4020	108	8950	240	15,560	417	32,300	866	42,430	1137	50,000	1340	
60		4.1	4800	129	10,850	291	18,870	506	39,600	1061	52,560	1409	54,000	1447	
80		5.5	6110	164	14,050	377	24,440	655	51,480	1380	72,000	1930	72,000	1930	
100		6.9	7400	198	17,020	456	29,600	793	59,840	1604	76,000	2037			
125		8.6	9020	242	20,730	556	36,050	966	70,570	1891					
150		10.3	10,630	285	24,440	655	42,500	1139	84,000	2251					
175		12.1	10,200	273	25,000	670	48,000	1286							
14 to 35 psig / 0.97 to 2.4 bar 35 psig / 2.4 bar ±1% psia / bar 19B0432X012 Zinc		40	2.8	2350	63.0	4790	128	8330	223	16,920	453	20,350	545	28,360	760
		50	3.4	3770	101	8300	222	14,430	387	29,690	796	42,740	1145	48,000	1286
	60	4.1	4700	126	10,510	282	18,270	490	38,050	1020	55,080	1476	60,000	1608	
	80	5.5	6120	164	14,000	375	24,350	653	51,600	1383	70,000	1876	74,000	1983	
	100	6.9	7400	198	17,020	456	29,600	793	63,630	1705	76,000	2037			
	125	8.6	9020	242	20,730	556	36,050	966	77,500	2077					
	150	10.3	10,630	285	24,440	655	42,500	1139	87,000	2332					
	175	12.1	11,200	300	25,500	683	49,000	1313							
	30 to 60 psig / 2.1 to 4.1 bar 40 psig / 2.8 bar ±1% psia / bar 19B0432X022 Green	50	3.4	1600	42.9	6500	174	9000	241	20,000	536	28,000	750	34,000	911
		60	4.1	2800	75.0	8170	219	17,000	456	33,000	884	48,000	1286	52,000	1394
80		5.5	5200	139	11,500	308	23,000	616	48,000	1286	66,000	1769	68,000	1822	
100		6.9	7600	204	13,500	362	29,000	777	31,000	831	76,000	2037			
125		8.6	8200	220	19,000	509	35,000	938	76,000	2037					
150		10.3	9800	263	22,750	610	42,000	1126	91,000	2439					
175		12.1	11,400	306	26,500	710	47,000	1260							
30 to 60 psig / 2.1 to 4.1 bar 50 psig / 3.4 bar ±1% psia / bar 19B0432X022 Green		60	4.1	3400	91.1	7000	188	10,000	268	21,000	563	32,000	858	45,000	1206
		80	5.5	5800	155	11,000	295	21,000	563	45,000	1206	69,000	1849	74,000	1983
		100	6.9	6200	166	15,000	402	26,000	697	59,000	1581	88,000	2358		
	125	8.6	8400	225	19,500	523	35,000	938	77,000	2064					
	150	10.3	9600	257	23,000	616	42,000	1126	89,000	2385					
	175	12.1	10,800	289	26,500	710	49,000	1313							
	30 to 60 psig / 2.1 to 4.1 bar 60 psig / 4.1 bar ±1% psia / bar 19B0432X022 Green	80	5.5	2800	75.0	3500	93.8	17,000	456	36,000	965	52,000	1394	53,000	1420
		100	6.9	3600	96.5	9500	255	23,000	616	50,000	1340	64,000	1715		
		125	8.6	2800	75.0	15,000	402	22,000	590	69,000	1849	90,000	2412		
		150	10.3	4600	123	11,000	295	18,000	482	89,000	2385				
175		12.1	6400	172	7000	188	18,000	482							
- Blank areas indicate where maximum operating inlet pressure for a given orifice size is exceeded.															
1. Downstream piping may affect actual capacity. It may be necessary to use enlarged downstream piping to obtain published capacities.															



299H Series

Table 8. Types 299HV and 299HVR Flow Capacities⁽¹⁾⁽²⁾ for 1-1/2 NPT and NPS 2 / DN 50 External/Dual Registration

OUTLET PRESSURE RANGE SETTING, CONTROL, SPRING PART NUMBER AND COLOR	INLET PRESSURE		CAPACITIES IN SCFH / Nm ³ /h OF 0.6 SPECIFIC GRAVITY NATURAL GAS														
			Orifice Size, In. / mm														
			1/4 x 3/8 / 6.4 x 9.5		3/8 / 9.5		1/2 / 13		3/4 / 19		7/8 / 22		1 / 25		1-3/16 / 30		
psig	bar	SCFH	Nm ³ /h	SCFH	Nm ³ /h	SCFH	Nm ³ /h	SCFH	Nm ³ /h	SCFH	Nm ³ /h	SCFH	Nm ³ /h	SCFH	Nm ³ /h		
3.5 to 6 in. w.c. / 9 to 15 mbar	2	0.14	750	20.1	1540	41.3	1960	52.5	4750	127							
	5	0.34	1150	30.8	2440	65.4	3230	86.6	7760	208	10,540	282	11,394	305	11,663	313	
	10	0.69	1580	42.3	3570	95.7	4970	133	11,660	312	15,614	418	18,162	487	18,972	508	
	15	1.0	1910	51.2	4400	118	6890	185	15,890	426	20,165	540	23,540	631	24,661	661	
	20	1.4	2230	59.8	5140	138	8050	216	18,570	498	23,993	643	28,127	754	31,438	843	
	25	1.7	2560	68.6	5880	158	9210	247	21,250	570	27,706	743	32,707	877	35,350	947	
	3.5 in. w.c. / 9 mbar -1 to 2 in. w.c. / -2 to 5 mbar T13707T0012 Black	30	2.1	2880	77.2	6630	178	10,370	278	23,930	641	31,108	834	38,218	1024	37,940	1017
		40	2.8	3520	94.3	8110	217	12,700	340	29,280	785	39,427	1057	46,259	1240	45,493	1219
		50	3.4	4170	112	9590	257	15,020	403	34,630	928	45,661	1224	48,253	1293	50,019	1341
		60	4.1	4810	129	11,080	297	17,340	465	39,990	1072	53,494	1434	53,859	1443	54,666	1465
80		5.5	6100	163	14,040	376	21,980	589	50,690	1358	67,139	1799					
100		6.9	7390	198	17,010	456	26,630	714	61,400	1646							
125		8.6	9010	241	20,720	555	32,430	869	74,780	2004							
150		10.3	10,620	285	24,430	655	38,240	1025	88,170	2363							
175		12.1	12,230	328	28,140	754	44,040	1180									
5 to 9 in. w.c. / 12 to 22 mbar		2	0.14	730	19.6	1490	39.9	1900	50.9	4610	124						
	5	0.34	1150	30.8	2420	64.9	3190	85.5	7690	206	10,393	279	11,742	315	11,620	311	
	10	0.69	1580	42.3	3570	95.7	4950	133	11,620	311	15,259	409	17,369	465	18,967	508	
	15	1.0	1910	51.2	4400	118	6890	185	15,890	426	20,561	551	23,554	631	25,175	675	
	20	1.4	2230	59.8	5140	138	8050	216	18,570	498	23,562	631	28,285	758	31,321	839	
	25	1.7	2560	68.6	5880	158	9210	247	21,250	570	27,267	731	31,977	857	37,818	1014	
	7 in. w.c. / 17 mbar -1 to 2 in. w.c. / -2 to 5 mbar T13589T0012 Yellow	30	2.1	2880	77.2	6630	178	10,370	278	23,930	641	30,848	827	37,113	995	38,935	1043
		40	2.8	3520	94.3	8110	217	12,700	340	29,280	785	38,318	1027	44,341	1188	47,918	1284
		50	3.4	4170	112	9590	257	15,020	403	34,630	928	47,466	1272	53,890	1444	56,081	1503
		60	4.1	4810	129	11,080	297	17,340	465	39,990	1072	53,039	1421	60,622	1625		
80		5.5	6100	163	14,040	376	21,980	589	50,690	1358	66,483	1782					
100		6.9	7390	198	17,010	456	26,630	714	61,400	1646							
125		8.6	9010	241	20,720	555	32,430	869	74,780	2004							
150		10.3	10,620	285	24,430	655	38,240	1025	88,170	2363							
175		12.1	12,230	328	28,140	754	44,040	1180									
7 to 20 in. w.c. / 17 to 50 mbar		2	0.14	690	18.5	1410	37.8	1790	48	4340	116						
	5	0.34	1130	30.3	2390	64.1	3130	83.9	7550	202	9764	262	11,452	307	12,284	329	
	10	0.69	1570	42.1	3550	95.1	4920	132	11,540	309	15,138	406	18,218	488	20,569	551	
	15	1.0	1910	51.2	4400	118	6890	185	15,890	426	19,519	523	23,109	619	27,205	729	
	20	1.4	2230	59.8	5140	138	8050	216	18,570	498	23,646	634	27,901	748	33,170	889	
	25	1.7	2560	68.6	5880	158	9210	244	21,250	570	27,241	730	33,164	889	40,850	1095	
	14 in. w.c. / 35 mbar ±2 in. w.c. / ±5 mbar 1N3112X0012 Unpainted	30	2.1	2880	77.2	6630	178	10,370	278	23,930	641	30,997	831	36,623	981	44,658	1197
		40	2.8	3520	94.3	8110	217	12,700	340	29,280	785	39,939	1070	45,847	1229	56,561	1516
		50	3.4	4170	112	9590	257	15,020	403	34,630	928	47,469	1272	54,427	1459	66,341	1778
		60	4.1	4810	129	11,080	297	17,340	465	39,990	1072	52,312	1402	62,894	1686		
80		5.5	6100	163	14,040	376	21,980	589	50,690	1358	68,196	1828	80,319	2153			
100		6.9	7390	198	17,010	456	26,630	714	61,400	1646	81,232	2177					
125		8.6	9010	241	20,720	555	32,430	869	74,780	2004							
150		10.3	10,620	285	24,430	655	38,240	1025	88,170	2363							
175		12.1	12,230	328	28,140	754	44,040	1180									
16 to 40 in. w.c. / 40 to 99 mbar		5	0.34	1100	29.5	2310	61.9	3010	80.7	7260	195						
	10	0.69	1560	41.8	3420	91.7	4680	125	11,180	300	15,468	415	18,194	460	21,680	574	
	15	1.0	1910	51.2	4400	118	6890	185	14,680	393	20,472	549	24,103	646	28,885	767	
	20	1.4	2230	59.8	5140	138	8050	216	18,570	498	23,136	620	28,103	748	33,028	889	
	25	1.7	2560	68.6	5880	158	9210	247	21,250	570	27,228	730	33,164	889	40,850	1095	
	28 in. w.c. / 70 mbar ±4 in. w.c. / ±10 mbar 1B413727222 Purple	30	2.1	2880	77.2	6630	178	10,370	278	23,930	641	31,435	842	32,859	881	43,473	1165
		40	2.8	3520	94.3	8110	217	12,700	340	29,280	785	39,248	1052	46,734	1252	53,601	1437
		50	3.4	4170	112	9590	257	15,020	403	34,630	928	47,246	1266	56,734	1522	62,712	1681
		60	4.1	4810	129	11,080	297	17,340	465	39,990	1072	53,504	1434	64,452	1727		
		80	5.5	6100	163	14,040	376	21,980	589	50,690	1358	68,415	1834				
100		6.9	7390	198	17,010	456	26,630	714	61,400	1646	84,001	2251					
125		8.6	9010	241	20,720	555	32,430	869	74,780	2004							
150		10.3	10,620	285	24,430	655	38,240	1025	88,170	2363							
175		12.1	12,230	328	28,140	754	44,040	1180									

Black areas indicate where maximum operating inlet pressure for a given orifice size is exceeded.
 1. Capacities are limited to 15,000 SCFH / 402 Nm³/h when the Type VSX8 is used without a control line.
 2. Due to slam-shut properties, capacities cannot be calculated with critical flow equation.



299H Series

Table 8. Types 299HV and 299HVR Flow Capacities⁽¹⁾⁽²⁾ for 1-1/2 NPT and NPS 2 / DN 50 External/Dual Registration (continued)

OUTLET PRESSURE RANGE SETTING, CONTROL, SPRING PART NUMBER AND COLOR	INLET PRESSURE		CAPACITIES IN SCFH/ Nm ³ /h OF 0.6 SPECIFIC GRAVITY NATURAL GAS														
			Orifice Size, In. / mm														
			1/4 x 3/8 / 6.4 x 9.5		3/8 / 9.5		1/2 / 13		3/4 / 19		7/8 / 22		1 / 25		1-3/16 / 30		
psig	bar	SCFH	Nm ³ /h	SCFH	Nm ³ /h	SCFH	Nm ³ /h	SCFH	Nm ³ /h	SCFH	Nm ³ /h	SCFH	Nm ³ /h	SCFH	Nm ³ /h		
1 to 3.25 psig / 69 mbar to 0.22 bar 2 psig / 0.14 bar ±1% psia / bar T13593T0012 Light blue	5	0.34	1010	27.1	2090	56.0	2690	72.1	6500	174							
	10	0.69	1540	41.3	3330	89.2	4500	121	10,780	289	14,222	381	15,686	420	15,919	427	
	15	1.00	1910	51.2	4350	117	6160	165	14,420	386	19,116	512	23,603	633	24,528	657	
	20	1.4	2230	59.8	5140	138	8050	216	18,570	498	23,217	622	27,076	726	30,146	808	
	25	1.7	2560	68.6	5880	158	9210	247	21,250	570	27,178	728	32,736	877	34,548	926	
	30	2.1	2880	77.2	6630	178	10,370	278	23,930	641	30,349	813	37,957	1017	40,482	1085	
	40	2.8	3520	94.3	8110	217	12,700	340	29,280	785	38,690	1037	46,362	1243	51,296	1375	
	50	3.4	4170	112	9590	257	15,020	403	34,630	928	46,334	1242	54,656	1465	60,987	1634	
	60	4.1	4810	129	11,080	297	17,340	465	39,990	1072	53,323	1429	63,150	1692	70,797	1897	
	80	5.5	6100	163	14,040	376	21,980	589	50,690	1358	67,640	1813	79,896	2141			
	100	6.9	7390	198	17,010	456	26,630	714	61,400	1646	80,643	2161					
	125	8.6	9010	241	20,720	555	32,430	869	74,780	2004							
	150	10.3	10,620	285	24,430	655	38,240	1024	88,170	2363							
	175	12.1	12,230	328	28,140	754	44,040	1180									
	2.75 to 6 psig / 0.19 to 0.41 bar 5 psig / 0.34 bar ±1% psia / bar T13671T0012 Orange	10	0.69	1380	37.0	2890	77.5	3780	101	9110	244						
		15	1.0	1860	49.8	4180	112	5690	152	13,370	358	16,755	449	20,355	546	20,759	556
		20	1.4	2230	59.8	5080	136	7170	192	16,790	450	21,483	576	25,610	686	28,316	759
25		1.7	2560	68.6	5880	158	9210	247	21,250	570	25,963	696	31,443	843	33,560	899	
30		2.1	2880	77.2	6630	178	10,370	278	23,930	641	29,934	802	35,739	958	39,000	1045	
40		2.8	3520	94.3	8110	217	12,700	340	29,280	785	38,424	1030	43,927	1177	50,866	1363	
50		3.4	4170	112	9590	257	15,020	403	34,630	928	44,529	1193	53,511	1434	58,608	1571	
60		4.1	4810	129	11,080	297	17,340	465	39,990	1072	52,347	1403	63,935	1713			
80		5.5	6100	163	14,040	376	21,980	589	50,690	1358	66,795	1790	79,794	2138			
100		6.9	7390	198	17,010	456	26,630	714	61,400	1646	79,208	2123					
125		8.6	9010	241	20,720	555	32,430	869	74,780	2004							
150		10.3	10,620	285	24,430	655	38,240	1024	88,170	2363							
175		12.1	12,230	328	28,140	754	44,040	1180									
5 to 16 psig / 0.34 to 1.1 bar 10 psig / 0.69 bar ±1% psia / bar T13600T0012 Red		15	1.0	1570	42.1	3270	87.6	4220	113	10,200	273						
		20	1.4	2120	56.8	4710	126	6310	169	14,850	398	16,629	446	22,183	595	22,421	601
		25	1.7	2530	67.8	5700	153	7890	211	18,510	496	27,996	750	27,255	730	28,275	758
		30	2.1	2880	77.2	6630	178	10,370	278	21,820	585	36,384	975	33,489	898	34,464	924
	40	2.8	3520	94.3	8110	217	12,700	340	29,280	785	44,427	1191	41,736	1119	44,446	1191	
	50	3.4	4170	112	9590	257	15,020	403	34,630	928	51,078	1369	50,865	1363	58,369	1564	
	60	4.1	4810	129	11,080	297	17,340	465	39,990	1072	66,891	1793	61,962	1661	68,137	1826	
	80	5.5	6100	163	14,040	376	21,980	589	50,690	1358	81,404	2182	79,036	2118			
	100	6.9	7390	198	17,010	456	26,630	714	61,400	1646	99,821	2675					
	125	8.6	9010	241	20,720	555	32,430	869	74,780	2004							
	150	10.3	10,620	285	24,430	655	38,240	1025	88,170	2363							
	175	12.1	12,230	328	28,140	754	44,040	1180									
	5 to 16 psig / 0.34 to 1.1 bar 15 psig / 1.0 bar ±1% psia / bar T13600T0012 Red	20	1.4	1740	46.6	3610	96.7	4640	124	11,210	300	11,950	320	12,660	339	11,555	310
		25	1.7	2350	63.0	5210	139	6890	185	16,220	435	17,299	464	13,716	368	22,563	605
		30	2.1	2810	75.3	6280	168	8560	229	20,110	539	26,131	700	23,285	624	29,827	799
		40	2.8	3520	94.3	8110	217	12,700	340	26,850	720	34,479	924	29,875	801	45,150	1210
		50	3.4	4170	112	9590	257	15,020	403	34,630	928	43,353	1162	39,753	1065	56,272	1508
60		4.1	4810	129	11,080	297	17,340	464	39,990	1072	51,751	1387	51,758	1387	65,725	1761	
80		5.5	6100	163	14,040	376	21,980	589	50,690	1358	65,973	1768	61,159	1639			
100		6.9	7390	198	17,010	456	26,630	714	61,400	1646	78,904	2115					
125		8.6	9010	241	20,720	555	32,430	869	74,780	2004							
150		10.3	10,620	285	24,430	655	38,240	1025	88,170	2363							
175		12.1	12,230	328	28,140	754	44,040	1180									

- Black areas indicate where maximum operating inlet pressure for a given orifice size is exceeded.

1. Capacities are limited to 15,000 SCFH / 402 Nm³/h when the Type VSX8 is used without a control line.

2. Due to slam-shut properties, capacities cannot be calculated with critical flow equation.



299H Series

Table 9. Types 299HV and 299HVR Flow Capacities⁽¹⁾⁽²⁾ for 1-1/2 NPT and NPS 2 / DN 50 Internal Registration

OUTLET PRESSURE RANGE SETTING, CONTROL, SPRING PART NUMBER AND COLOR	INLET PRESSURE		CAPACITIES IN SCFH / Nm ³ /h OF 0.6 SPECIFIC GRAVITY NATURAL GAS												
			Orifice Size, In. / mm												
			1/4 x 3/8 / 6.4 x 9.5		3/8 / 9.5		1/2 / 13		3/4 / 19		1 / 25		1-3/16 / 30		
psig	bar	SCFH	Nm ³ /h	SCFH	Nm ³ /h	SCFH	Nm ³ /h	SCFH	Nm ³ /h	SCFH	Nm ³ /h	SCFH	Nm ³ /h		
3.5 to 6 in. w.c. / 9 to 15 mbar	2	0.14	760	20.4	1780	47.7	2800	75	6460	173	6560	176	5783	155	
	5	0.34	1160	31.1	2450	65.7	4000	107	7140	191	8126	218	11,983	321	
	10	0.69	1590	42.6	3560	95.4	6000	161	7140	191	6448	173	16,515	443	
	15	1.0	1920	51.5	4400	118	7500	201	8320	223	15,728	422	21,277	570	
	20	1.4	2240	60.0	5100	137	9000	241	10,830	290	20,783	557	17,610	472	
	25	1.7	2570	68.9	5450	146	7620	204	9870	265	30,763	824	16,968	455	
	3.5 in. w.c. / 9 mbar -1 to 2 in. w.c. / -2 to 5 mbar T13707T0012 Black	30	2.1	2890	77.5	5800	155	9880	265	9870	265	30,366	814	17,571	471
		40	2.8	3530	94.6	7550	202	12,070	323	6400	172	17,055	457	28,457	763
		50	3.4	3880	104	9300	249	11,300	303	6840	183	9825	263	12,505	335
		60	4.1	4090	110	7700	206	6660	178	7010	188	4041	108	10,672	286
80		5.5	3110	83.3	2800	75	1230	33	9000	241	5199	139			
100		6.9	4790	128	3600	97.0	2990	80	4650	125	4374	117			
125		8.6	5210	140	3600	97.0	4090	110	3230	87					
150		10.3	5640	151	3600	97.0	5210	140	3230	87					
175	12.1	7310	196	5680	152	7300	196								
5 to 9 in. w.c. / 12 to 22 mbar	2	0.14	750	20.1	1890	50.7	2800	75	5520	148					
	5	0.34	1120	30.0	2460	65.9	4000	107	6020	161	8254	221	11,576	310	
	10	0.69	1590	42.6	3400	91.1	6000	161	6520	175	11,345	304	13,793	370	
	15	1.0	1920	51.5	4320	116	7000	188	8000	214	15,571	417	19,851	532	
	20	1.4	2240	60.0	5060	136	9000	241	7930	213	20,425	547	16,104	432	
	25	1.7	2570	68.9	5800	155	9690	260	7420	199	24,997	670	16,019	429	
	7 in. w.c. / 17 mbar -1 to 2 in. w.c. / -2 to 5 mbar T13589T0012 Yellow	30	2.1	2890	77.5	6500	174	10,480	281	7050	189	27,772	744	16,648	446
		40	2.8	3530	94.6	7900	212	11,490	308	4900	131	100	3	27,833	746
		50	3.4	4180	112	7800	209	10,280	276	5940	159	17,431	467	12,059	323
		60	4.1	4820	129	6560	176	7170	192	6310	169	10,160	272	10,193	273
80		5.5	4020	108	2620	70.0	1200	32	8340	224	5,330	143			
100		6.9	4670	125	3420	92.0	2990	80	3900	105	4535	122			
125		8.6	5070	136	3600	97.0	5180	139	3360	90					
150		10.3	5480	147	3870	104	5180	139	2340	63					
175	12.1	6430	172	5120	137	7300	196								
7 to 20 in. w.c. / 17 to 50 mbar	2	0.14	700	18.8	1420	38.1	3440	92.2	4790	128			4762	128	
	5	0.34	1110	29.7	2200	59.0	4000	107	6080	163	10,790	289	11,429	306	
	10	0.69	1580	42.3	3500	93.8	6000	161	7440	199	11,629	312	13,361	358	
	15	1.0	1920	51.5	4300	115	7600	204	9250	248	15,212	408	19,037	510	
	20	1.4	2240	60.0	5000	134	9000	241	10,670	286	20,121	539	19,644	526	
	25	1.7	2570	68.9	5700	153	10,000	268	8950	240	23,600	632	18,515	496	
	14 in. w.c. / 35 mbar ±2 in. w.c. / ±5 mbar 1N3112X0012 Unpainted	30	2.1	2890	77.5	6500	174	11,200	300	8450	226	26,579	712	19,121	512
		40	2.8	3530	94.6	7900	212	11,620	311	6800	182	23,140	620	29,888	801
		50	3.4	4180	112	9300	249	12,400	332	7240	194	19,015	510	12,707	341
		60	4.1	4820	129	7490	201	12,090	324	7400	198	15,119	405	11,074	297
80		5.5	4600	123	2730	73.0	2030	54	7420	199					
100		6.9	4970	133	3900	105	4410	118	4970	133					
125		8.6	5200	139	3900	105	5990	161	4330	116					
150		10.3	5430	146	3900	105	5990	161	3120	84					
175	12.1	4700	126	3900	105	6310	169								
16 to 40 in. w.c. / 40 to 99 mbar	5	0.34	1110	29.7	2600	69.7	3600	96.5	5200	139	9528	255	9677	259	
	10	0.69	1570	42.1	3500	93.8	6000	161	6910	185	17,268	463	18,587	498	
	15	1.0	1920	51.5	4400	118	7200	193	9370	251	18,027	483	24,955	669	
	20	1.4	2240	60.0	5100	137	8800	236	11,030	296	21,638	580	28,078	752	
	25	1.7	2570	68.9	5800	155	10,000	268	11,390	305	24,673	661	23,468	629	
	28 in. w.c. / 70 mbar ±4 in. w.c. / ±10 mbar 1B413727222 Purple	30	2.1	2890	77.5	6500	174	11,600	311	11,980	321	27,545	738	23,110	619
		40	2.8	3530	94.6	7900	212	13,570	364	11,220	301	26,603	713	32,005	858
		50	3.4	4180	112	9300	249	13,920	373	10,020	269	21,460	575	34,089	914
		60	4.1	4820	129	8250	221	14,410	386	9170	246	18,221	488	13,112	351
		80	5.5	6110	164	4260	114	3090	83	11,320	303	13,875	372		
100		6.9	6360	170	5150	138	4850	130	3750	101	12,844	344			
125		8.6	6450	173	5930	159	5290	142	3960	106					
150		10.3	6540	175	6110	164	5570	149	2520	68					
175	12.1	2950	79	3560	95.0	3320	89.0								

■ - Black areas indicate where maximum operating inlet pressure for a given orifice size is exceeded.

1. Capacities are limited to 15,000 SCFH / 402 Nm³/h when the Type VSX8 is used without a control line.

2. Due to slam-shut properties, capacities cannot be calculated with critical flow equation.

- continued -



299H Series

Table 9. Types 299HV and 299HVR Flow Capacities⁽¹⁾⁽²⁾ for 1-1/2 NPT and NPS 2 / DN 50 Internal Registration (continued)

OUTLET PRESSURE RANGE SETTING, CONTROL, SPRING PART NUMBER AND COLOR	INLET PRESSURE		CAPACITIES IN SCFH / Nm ³ /h OF 0.6 SPECIFIC GRAVITY NATURAL GAS												
			Orifice Size, In. / mm												
			1/4 x 3/8 / 6.4 x 9.5		3/8 / 9.5		1/2 / 13		3/4 / 19		1 / 25		1-3/16 / 30		
psig	bar	SCFH	Nm ³ /h	SCFH	Nm ³ /h	SCFH	Nm ³ /h	SCFH	Nm ³ /h	SCFH	Nm ³ /h	SCFH	Nm ³ /h		
1 to 3.25 psig / 69 mbar to 0.22 bar 2 psig / 0.14 bar ±1% psia / bar T13593T0012 Light blue	5	0.34	1020	27.3	2900	77.7	4000	107	5660	152	10,146	272	3	0	
	10	0.69	1550	41.5	3600	96.5	5500	147	7,840	210	16,652	446	18,337	491	
	15	1.0	1920	51.5	4300	115	7500	201	10,210	273	16,884	452	23,809	638	
	20	1.4	2240	60.0	5000	134	8500	228	12,100	324	20,709	555	28,791	772	
	25	1.7	2570	68.9	5550	149	10,000	268	11,880	318	24,308	651	31,522	845	
	30	2.1	2890	77.5	6100	163	11,000	295	12,800	343	27,520	738	24,784	664	
	40	2.8	3530	94.6	7750	208	14,000	375	13,960	374	33,891	908	26,046	698	
	50	3.4	4180	112	9400	252	14,380	385	10,940	293	19,543	524	36,155	969	
	60	4.1	4820	129	10,530	282	15,510	416	9810	263	21,023	563	20,026	537	
	80	5.5	6110	164	8580	230	12,000	322	3700	99	14,926	400			
	100	6.9	6850	184	3290	88	1130	30	2910	78					
	125	8.6	7070	189	3050	82	2220	60	2910	78					
	150	10.3	7300	196	3200	86	2090	56	2910	78					
	175	12.1	4560	122	5540	148	2090	56							
	2.75 to 6 psig / 0.19 to 0.41 bar 5 psig / 0.34 bar ±1% psia / bar T13671T0012 Orange	10	0.69	1390	37.3	2800	75	5000	134	6540	175	13,850	371	11,743	315
15		1.0	1870	50.1	3750	101	7000	188	9680	259	20,557	551	21,885	587	
20		1.4	2240	60.0	4700	126	8500	228	11,480	308	25,547	685	28,040	751	
25		1.7	2570	68.9	5700	153	9500	255	12,420	333	22,097	592	32,687	876	
30		2.1	2890	77.5	6430	172	11,000	295	13,050	350	27,576	739	37,211	997	
40		2.8	3530	94.6	7900	212	13,000	348	15,780	423	33,919	909	29,920	802	
50		3.4	4180	112	9300	249	16,000	429	15,110	405	35,931	963	30,031	805	
60		4.1	4790	128	10,700	287	15,200	407	10,710	287	31,207	836	41,617	1115	
80		5.5	5740	154	13,350	358	13,170	353	8670	232	21,999	590			
100		6.9	6680	179	16,000	429	2,430	65	8670	232	15,606	418			
125		8.6	7170	192	4740	127	1700	46	7300	196					
150		10.3	7650	205	3530	95	1910	51	6470	173					
175		12.1	4400	118	3530	95	3050	82							
5 to 16 psig / 0.34 to 1.1 bar 10 psig / 0.69 bar ±1% psia / bar T13600T0012 Red		15	1.0	1800	48.2	3200	85.8	4000	107	7250	194	11,639	312	14,732	395
		20	1.4	2200	59	4300	115	12,000	322	9870	265	22,403	600	23,228	623
	25	1.7	2600	69.7	5400	145	9000	241	12,240	328	26,281	704	27,637	741	
	30	2.1	3000	80.4	6600	177	10,000	268	13,490	362	28,080	753	35,678	956	
	40	2.8	3650	97.8	7800	209	13,000	348	17,230	462	36,123	968	44,046	1180	
	50	3.4	4300	115	9000	241	16,000	429	18,520	496	41,283	1106	49,610	1330	
	60	4.1	4950	133	10,460	280	16,050	430	20,460	548	44,057	1181	35,915	963	
	80	5.5	6250	168	13,400	359	15,950	427	10,780	289	37,078	994	54,401	1458	
	100	6.9	7600	204	16,110	432	15,030	403	11,250	302	30,874	827			
	125	8.6	9300	249	19,500	553	16,250	436	11,250	302					
	150	10.3	6320	169	4960	133	1970	53	6590	177					
	175	12.1	5810	156	3270	88	1970	53							
	5 to 16 psig / 0.34 to 1.1 bar 15 psig / 1.0 bar ±1% psia / bar T13600T0012 Red	20	1.4	1900	50.9	3400	91.1	6000	161	8,860	237	15,265	409	15,327	411
		25	1.7	2450	65.7	4550	122	8000	214	10,900	292	24,397	654	24,228	649
		30	2.1	3000	80.4	5700	153	10,000	268	13,870	372	30,686	822	31,796	852
40		2.8	3700	99.2	7600	204	13,000	348	19,100	512	31,184	836	44,116	1182	
50		3.4	4320	116	8900	239	15,000	402	20,300	544	39,146	1049	53,217	1426	
60		4.1	4950	133	10,330	277	16,900	453	20,660	554	44,294	1187	58,091	1557	
80		5.5	6200	166	13,200	354	18,730	502	21,940	588	50,086	1342	46,125	1236	
100		6.9	7350	197	16,000	429	21,260	570	16,310	437	42,814	1147			
125		8.6	8800	236	19,500	523	23,920	641	13,970	374					
150		10.3	10,220	274	22,950	615	25,900	694	10,600	284					

- Black areas indicate where maximum operating inlet pressure for a given orifice size is exceeded.

1. Capacities are limited to 15,000 SCFH / 402 Nm³/h when the Type VSX8 is used without a control line.

2. Due to slam-shut properties, capacities cannot be calculated with critical flow equation.



299H Series

Table 10. Types 299HV and 299HVR Flow Capacities⁽¹⁾⁽²⁾ for 2 NPT Internal Registration

OUTLET PRESSURE RANGE SETTING, CONTROL, SPRING PART NUMBER AND COLOR	INLET PRESSURE		CAPACITIES IN SCFH / Nm ³ /h OF 0.6 SPECIFIC GRAVITY NATURAL GAS											
			Orifice Size, In. / mm											
			1/4 x 3/8 / 6.4 x 9.5		3/8 / 9.5		1/2 / 13		3/4 / 19		1 / 25		1-3/16 / 30	
psig	bar	SCFH	Nm ³ /h	SCFH	Nm ³ /h	SCFH	Nm ³ /h	SCFH	Nm ³ /h	SCFH	Nm ³ /h	SCFH	Nm ³ /h	
3.5 to 6 in. w.c. / 9 to 15 mbar	2	0.14	760	20.4	1780	47.7	2800	75	6460	173	5606	150	5922	159
	5	0.34	1160	31.1	2450	65.7	4000	107	7600	204	10,320	277	11,844	317
	10	0.69	1590	42.6	3560	95.4	6000	161	9500	255	8869	238	9910	266
	15	1.0	1920	51.5	4400	118	7500	201	12,400	332	10,603	284	11,972	321
	20	1.4	2240	60.0	5100	137	9000	241	17,500	469	11,396	305	14,038	376
	25	1.7	2570	68.9	5450	146	8000	214	17,000	456	11,940	320	16,853	452
3.5 in. w.c. / 9 mbar -1 to 2 in. w.c. / -2 to 5 mbar T13707T0012 Black	30	2.1	2890	77.5	5800	155	11,000	295	17,000	456	11,676	313	18,544	497
	40	2.8	3530	94.6	7550	202	14,000	375	13,000	348	9852	264	13,471	361
	50	3.4	3880	104	9300	249	16,500	442	13,000	348	15,049	403	10,859	291
	60	4.1	4090	110	7700	206	12,000	322	12,400	332	9677	259	9901	265
	80	5.5	3110	83.3	4500	121	3500	94	11,600	311	6486	174		
	100	6.9	4790	128	4500	121	3750	101	6000	161	4000	107		
	125	8.6	5210	140	4500	121	5120	137	4400	118				
	150	10.3	5620	151	4500	121	6500	174	4400	118				
175	12.1	5620	151	4500	121	6500	174							
5 to 9 in. w.c. / 12 to 22 mbar 7 in. w.c. / 17 mbar -1 to 2 in. w.c. / -2 to 5 mbar T13589T0012 Yellow	2	0.14	750	20.1	1890	50.7	2800	75	5520	148			4569	122
	5	0.34	1120	30.0	2460	65.9	4000	107	7200	193	10,252	275	11,314	303
	10	0.69	1590	42.6	3400	91.1	6000	161	10,000	268	9,207	247	10,232	274
	15	1.0	1920	51.5	4320	116	7000	188	13,600	364	10,685	286	12,452	334
	20	1.4	2240	60.0	5060	136	9000	241	14,000	375	11,892	319	13,958	374
	25	1.7	2570	68.9	5800	155	10,000	268	15,000	402	11,949	320	16,366	439
	30	2.1	2890	77.5	6500	174	11,250	302	16,000	429	11,574	310	18,492	496
	40	2.8	3530	94.6	7900	212	13,000	348	10,400	279	11,780	316	13,165	353
	50	3.4	4180	112	7800	209	14,500	389	10,400	279	17,726	475	10,835	290
	60	4.1	4180	112	6560	176	12,250	328	10,400	279	9838	264	10,216	274
80	5.5	4020	108	4100	110	3250	87	10,400	279					
100	6.9	4670	125	4270	114	3750	101	5200	139					
125	8.6	5070	136	4500	121	6500	174	4400	118					
150	10.3	5480	147	4850	130	6500	174	4400	118					
175	12.1	5480	147	5200	139	6500	174							
7 to 20 in. w.c. / 17 to 50 mbar 14 in. w.c. / 35 mbar ±2 in. w.c. / ±5 mbar 1N3112X0012 Unpainted	2	0.14	700	18.8	1420	38.1	3440	92.2	4800	129				
	5	0.34	1110	29.7	2200	59	4000	107	7200	193	9773	262	11,480	308
	10	0.69	1580	42.3	3500	93.8	6000	161	11,200	300	9366	251	11,502	308
	15	1.0	1920	51.5	4300	115	7600	204	15,200	407	11,161	299	13,850	371
	20	1.4	2240	60.0	5000	134	9000	241	18,000	482	12,750	342	25,753	690
	25	1.7	2570	68.9	5700	153	10,000	268	17,200	461	13,890	372	26,576	712
	30	2.1	2890	77.5	6500	174	11,200	300	18,200	488	16,214	435	26,082	699
	40	2.8	3530	94.6	7900	212	12,800	343	14,400	386	22,043	591	24,392	654
	50	3.4	4180	112	9300	249	16,400	440	14,400	386	20,925	561	12,252	328
	60	4.1	4820	129	7630	204	18,800	504	14,000	375	17,782	477	10,689	286
	80	5.5	4600	123	4300	115	5000	134	8400	225	8924	239		
	100	6.9	4970	133	4430	119	5000	134	6000	161				
125	8.6	5200	139	4600	123	6800	182	6000	161					
150	10.3	5430	146	4850	130	6800	182	6000	161					
175	12.1	5430	146	5100	137	6800	182							
16 to 4 in. w.c. / 40 to 99 mbar 28 in. w.c. / 70 mbar ±4 in. w.c. / ±10 mbar 1B413727222 Purple	5	0.34	1110	29.7	2600	69.7	3600	96.5	6500	174	10,863	291	10,774	289
	10	0.69	1570	42.1	3500	93.8	6000	161	10,000	268	17,444	467	17,697	474
	15	1.0	1920	51.5	4400	118	7200	193	14,500	389	14,348	385	22,216	595
	20	1.4	2240	60.0	5100	137	8800	236	17,500	469	15,587	418	27,214	729
	25	1.7	2570	68.9	5800	155	10,000	268	20,000	536	18,194	488	29,193	782
	30	2.1	2890	77.5	6500	174	11,600	311	23,500	630	21,824	585	29,364	787
	40	2.8	3530	94.6	7900	212	14,000	375	22,500	603	33,884	908	27,850	746
	50	3.4	4180	112	9300	249	16,400	440	20,000	536	36,019	965	28,517	764
	60	4.1	4820	129	8400	225	19,000	509	16,500	442	36,145	969	29,267	784
	80	5.5	6110	164	6600	177	6500	174	16,500	442	12,286	329		
	100	6.9	6360	170	6910	185	6500	174	7000	188				
	125	8.6	6450	173	7300	196	6500	174	7000	188				
150	10.3	6540	175	7700	206	7000	188	7000	188					
175	12.1	6540	175	8100	217	7000	188							

Black areas indicate where maximum operating inlet pressure for a given orifice size is exceeded.

1. Capacities are limited to 15,000 SCFH / 402 Nm³/h when the Type VSX8 is used without a control line.

2. Due to slam-shut properties, capacities cannot be calculated with critical flow equation.

- continued -



299H Series

Table 10. Types 299HV and 299HVR Flow Capacities⁽¹⁾⁽²⁾ for 2 NPT Internal Registration (continued)

OUTLET PRESSURE RANGE SETTING, CONTROL, SPRING PART NUMBER AND COLOR	INLET PRESSURE		CAPACITIES IN SCFH / Nm ³ /h OF 0.6 SPECIFIC GRAVITY NATURAL GAS											
			Orifice Size, In. / mm											
			1/4 x 3/8 / 6.4 x 9.5		3/8 / 9.5		1/2 / 13		3/4 / 19		1 / 25		1-3/16 / 30	
psig	bar	SCFH	Nm ³ /h	SCFH	Nm ³ /h	SCFH	Nm ³ /h	SCFH	Nm ³ /h	SCFH	Nm ³ /h	SCFH	Nm ³ /h	
1 to 3.25 psig / 69 mbar to 0.22 bar 2 psig / 0.14 bar ±1% psia / bar T13593T0012 Light blue	5	0.34	1020	27.3	2900	77.7	4000	107	6000	161				
	10	0.69	1550	41.5	3600	96.5	5500	147	10,500	281				
	15	1.0	1920	51.5	4300	115	7500	201	14,500	389				
	20	1.4	2240	60.0	5000	134	8500	228	18,000	482				
	25	1.7	2670	71.6	5550	149	10,000	268	20,000	536				
	30	2.1	2890	77.5	6100	163	11,000	295	24,000	643				
	40	2.8	3530	94.6	7750	208	14,000	375	28,000	750				
	50	3.4	4180	112	9400	252	16,000	429	23,000	616				
	60	4.1	4820	129	10,730	288	19,000	509	18,000	482				
	80	5.5	6110	164	13,400	359	24,000	643	8000	214				
2.75 to 6 psig / 0.19 to 0.41 bar 5 psig / 0.34 bar ±1% psia / bar T13671T0012 Orange	100	6.9	6850	184	10,770	289	6500	174	8000	214				
	125	8.6	7070	189	7500	201	7500	201	8000	214				
	150	10.3	7300	196	7500	201	7500	201	9500	255				
	175	12.1	7300	196	7500	201	7500	201						
	10	0.69	1390	37.3	2800	75	5000	134	8000	214				
	15	1.0	1870	50.1	3750	101	7000	188	13,000	348				
	20	1.4	2240	60.0	4700	126	8500	228	17,000	456				
	25	1.7	2570	68.9	5700	153	9500	255	20,000	536				
	30	2.1	2890	77.5	6430	172	11,000	295	23,000	616				
	40	2.8	3530	94.6	7900	212	13,000	348	29,000	777				
5 to 16 psig / 0.34 to 1.1 bar 10 psig / 0.69 bar ±1% psia / bar T13600T0012 Red	50	3.4	4180	112	9300	249	16,000	429	30,000	804				
	60	4.1	4790	128	10,700	287	18,000	482	20,000	536				
	80	5.5	5740	154	13,350	358	23,000	616	20,000	536				
	100	6.9	6680	179	16,000	429	8000	214	20,000	536				
	125	8.6	7170	192	12,800	343	8000	214	20,000	536				
	150	10.3	7650	205	9600	257	8000	214	20,000	536				
	175	12.1	7650	205	9600	257	8000	214						
	15	1.0	1800	48.2	3200	85.8	4000	107	8500	228				
	20	1.4	2200	59	4300	115	12,000	322	14,000	375	20,857	559	22,041	591
	25	1.7	2600	69.7	5400	145	9000	241	19,000	509	22,081	592	26,422	708
15 psig / 1.0 bar ±1% psia / bar T13600T0012 Red	30	2.1	3000	80.4	6600	177	10,000	268	22,000	590	22,228	596	34,273	919
	40	2.8	3650	97.8	7800	209	13,000	348	28,000	750	29,015	778	40,155	1076
	50	3.4	4300	115	9000	241	16,000	429	34,000	911	30,428	815	45,392	1217
	60	4.1	4950	133	10,460	280	18,000	482	39,000	1045	47,113	1263	46,916	1257
	80	5.5	6250	168	13,400	359	23,000	616	25,000	670	57,406	1538	46,983	1259
	100	6.9	7600	204	16,110	432	29,000	777	25,000	670	60,228	1614		
	125	8.6	9300	249	19,500	523	35,000	938	25,000	670				
	150	10.3	9,900	265	15,050	403	10,000	268	25,000	670				
	175	12.1	10,500	281	10,600	284	10,000	268						
	5 to 16 psig / 0.34 to 1.1 bar 15 psig / 1.0 bar ±1% psia / bar T13600T0012 Red	20	1.4	1900	50.9	3400	91.1	6000	161	10,000	268			
25		1.7	2450	65.7	4550	122	8000	214	15,000	402	22,951	615	24,816	665
30		2.1	3000	80.4	5700	153	10,000	268	20,000	536	27,742	743	29,280	785
40		2.8	3700	99.2	7600	204	13,000	348	28,000	750	24,420	654	41,172	1103
50		3.4	4320	116	8900	239	15,000	402	35,000	938	30,384	814	37,525	1006
60		4.1	4950	133	10,330	277	18,000	482	40,000	1072	35,110	941	53,476	1433
80		5.5	6200	166	13,200	354	23,000	616	51,000	1367	56,966	1527	53,793	1442
100		6.9	7350	197	16,000	429	29,000	777	35,000	938	65,280	1750		
125		8.6	8800	236	19,500	523	36,000	965	30,000	804				
150		10.3	10,220	274	22,950	615	40,000	1072	30,000	804				
175	12.1	11,650	312	26,400	708	40,000	1072							

- Black areas indicate where maximum operating inlet pressure for a given orifice size is exceeded.

1. Capacities are limited to 15,000 SCFH / 402 Nm³/h when the Type VSX8 is used without a control line.

2. Due to slam-shut properties, capacities cannot be calculated with critical flow equation.



299H Series

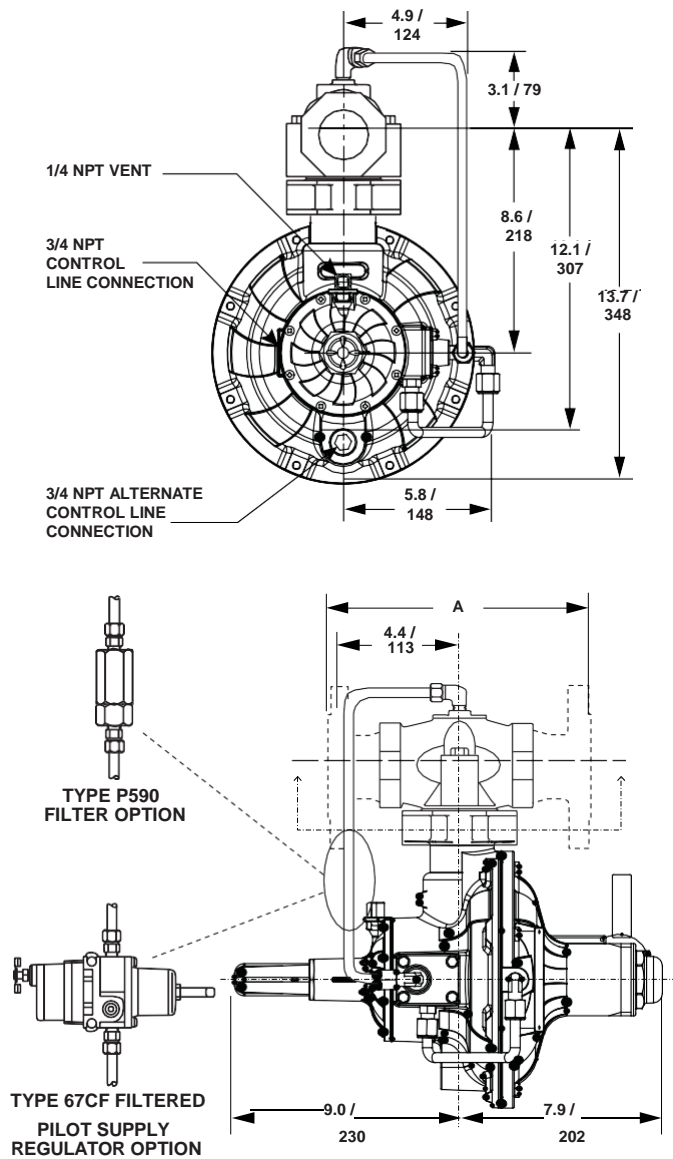

A7274

IN. /
mm

Figure 8. Types 299H and 299HR Dimensions

Table 11. Types 299H and 299HR Dimensions

DIMENSION	END CONNECTION STYLE AND FACE-TO-FACE DIMENSION											
	NPT		CL125 FF ⁽¹⁾		CL125 FF		CL150 RF		CL250 RF ⁽²⁾		PN 10 or 16 ⁽²⁾	
	In.	mm	In.	mm	In.	mm	In.	mm	In.	mm	In.	mm
A	6.12	155	7.50	199	10.00	254	10.00	254	10.50	267	9.06	230

1. Available in Cast iron only.
2. Available in Ductile iron only.



299H Series

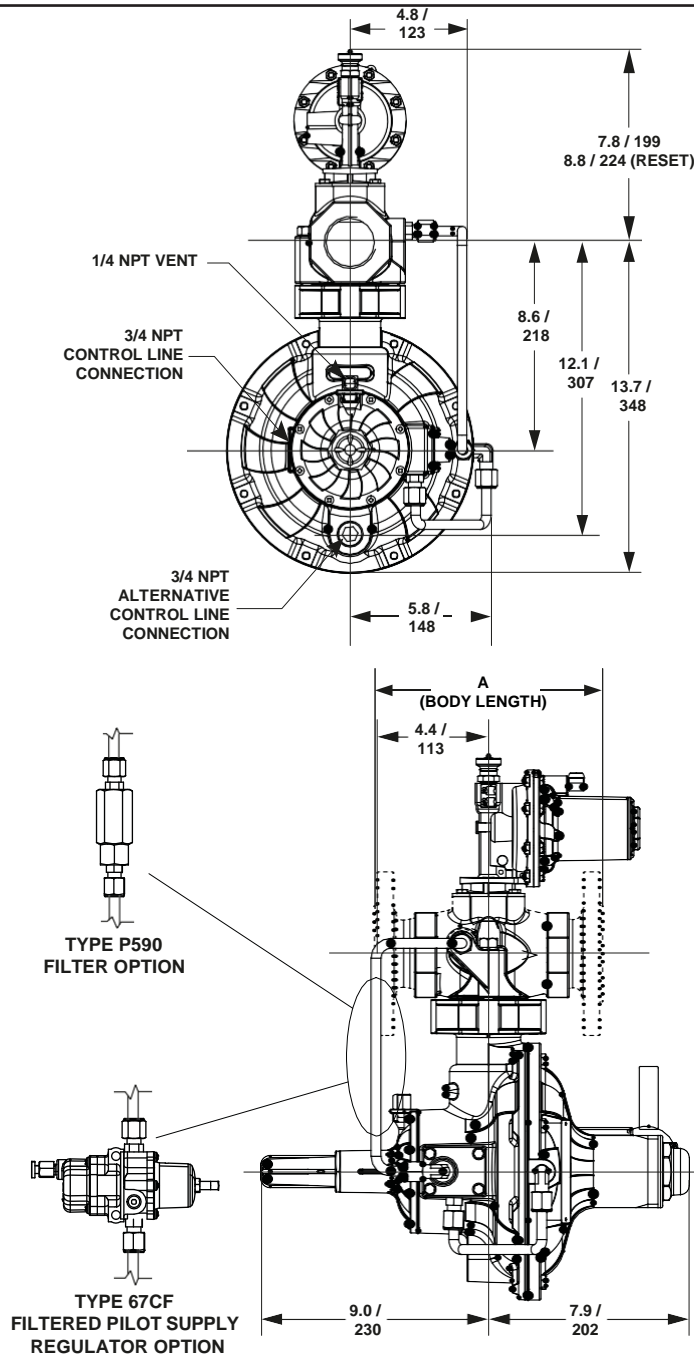

ERAA23274_AB

IN. / mm

Figure 9. Types 299HV and 299HVR Dimensions

Table 12. Types 299HV and 299HVR Dimensions

DIMENSION	BODY SIZE AND END CONNECTION											
	1-1/2 NPT				2 NPT		NPS 2 / DN 50					
	CL125 RF		CL250 RF		PN 10/16 RF							
	In.	mm	In.	mm	In.	mm	In.	mm	In.	mm		
A	6.12	155	6.12	155	10.00	254	10.50	267	9.06	230		



299H Series

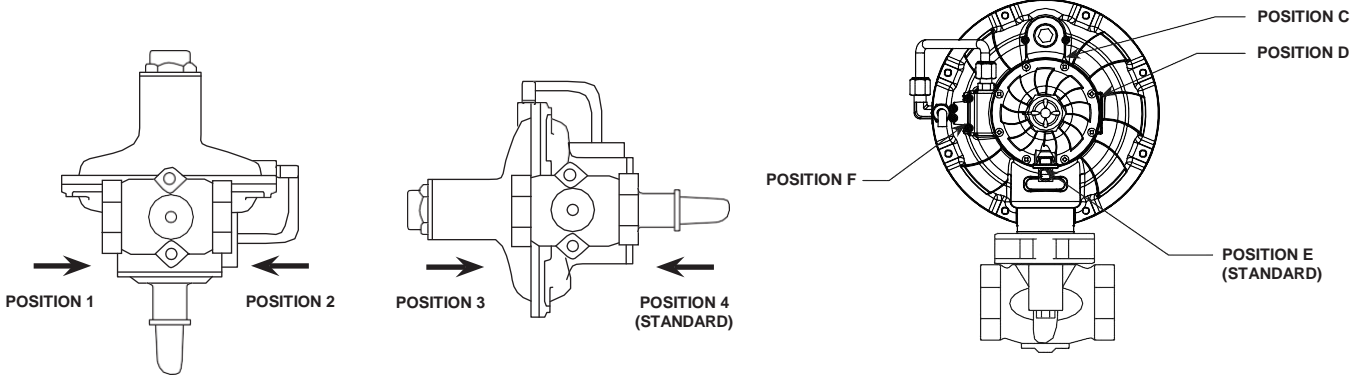

Figure 10. Body and Vent Positions

Ordering Information

To order, complete the Ordering Guide on pages 31 and 32. Carefully review the Specifications section on page 2 and specify the desired selection whenever there is a choice to be made.

Ordering Guide

Type (Select One)

- 299H***
- 299HR***
- 299HV***
- 299HVR***

Body Size, Material and End Connection Style (Select One)

1-1/4 NPT

- Grey cast iron (For Types 299H and 299HR only)***

1-1/2 NPT

- Grey cast iron (For Types 299H and 299HR only)***
- Ductile iron***
- Steel (For Types 299H and 299HR only)***

NPS 2 / DN 50

Grey cast iron (For Types 299H and 299HR only)

- NPT***
- CL125 FF - 7.5 in. / 191 mm***
- CL125 FF - 10 in. / 254 mm***

Ductile iron

- NPT***
- CL125 FF - 10 in. / 254 mm***
- CL250 RF***
- PN 10/16 Flanged*

Steel (For Types 299H and 299HR only)

- NPT***
- CL150 RF***

Orifice Size (Select One)

- 1/4 x 3/8 in. / 6.4 x 9.5 mm***
- 3/8 in. / 9.5 mm***
- 1/2 in. / 13 mm***
- 3/4 in. / 19 mm***
- 7/8 in. / 22 mm (For Types 299H and 299HR only)***
- 1 in. / 25 mm (For Types 299H and 299HR only)***
- 1-3/16 in. / 30 mm (For Types 299H and 299HR only)***

Outlet Pressure Range (Select One)

- 3.5 to 6 in. w.c. / 9 to 15 mbar, Black***
- 5 to 9 in. w.c. / 12 to 22 mbar, Yellow***
- 7 to 20 in. w.c. / 17 to 50 mbar, Unpainted***
- 16 to 40 in. w.c. / 40 to 99 mbar, Purple***
- 1 to 3.25 psig / 69 mbar to 0.22 bar, Light Blue***
- 2.75 to 6 psig / 0.19 to 0.41 bar, Orange***
- 5 to 16 psig / 0.34 to 1.1 bar, Red***
- 14 to 35 psig / 0.97 to 2.4 bar (Type 299H), Zinc***
- 30 to 60 psig / 2.1 to 4.1 bar (Type 299H), Green***

Pressure Registration (Select One)

- Internal***
- External***
- Dual***

Fixed Restriction (Select One)

- 0.044 in. / 1.1 mm, Red (standard gain)***
- 0.071 in. / 1.8 mm, Green (low gain)***
- 0.082 in. / 2.1 mm, Blue (lower gain)***

VSX Series Slam-Shut Trip Pressure Setting

(Select one if applicable and specify setpoint/s, see Tables 4a, 4b, 4c and 4d.)

Overpressure Protection Only (OPSO)

- Supply setpoint required _____

- continued -



299H Series

Ordering Guide (continued)

Overpressure and Underpressure Protection (OPSO/UPSO)

- Supply overpressure setpoint required
- Supply underpressure setpoint required

Type P590 Pilot Supply Filter (Optional)

- Type P593-1, Aluminum
- Type 594-1, Brass

Type 67CF Filtered Pilot Supply Regulator (Optional)

- Yes, please add a Type 67CF regulator to this order.

Main Valve Parts Kit (Optional)

- Yes, please send one parts kit to match this order.

Pilot Parts Kit (Optional)

- Yes, please send one parts kit to match this order.

Regulators Quick Order Guide	
***	Standard - Readily Available for Shipment
**	Non-Standard - Allow Additional Time for Shipment
*	Special Order, Constructed from Non-Stocked Parts. Consult your local Sales Office for Availability.
Availability of the product being ordered is determined by the component with the longest shipping time for the requested construction.	

Specification Worksheet

Application (Please designate units):
 Specific Use _____
 Line Size _____
 Gas Type and Specific Gravity _____
 Gas Temperature _____
 Does the Application Require Overpressure Protection?
 No Yes, if so, which is preferred:
 Relief Valve Monitor Regulator Shutoff Device
 Is overpressure protection equipment selection assistance desired? _____

Pressure (Please designate units):
 Maximum Inlet Pressure (P_{1max}) _____
 Minimum Inlet Pressure (P_{1min}) _____
 Downstream Pressure Setting(s) (P_2) _____
 Maximum Flow (Q_{max}) _____

Performance Required:
 Accuracy Requirements? _____
 Need for Extremely Fast Response? _____

Other Requirements: _____

✉ Webadmin.Regulators@emerson.com

🔍 Fisher.com

📘 Facebook.com/EmersonAutomationSolutions

🌐 LinkedIn.com/company/emerson-automation-solutions

🐦 Twitter.com/emr_automation

Emerson Automation Solutions

Americas

McKinney, Texas 75070 USA
T +1 800 558 5853
+1 972 548 3574

Europe

Bologna 40013, Italy
T +39 051 419 0611

Asia Pacific

Singapore 128461, Singapore
T +65 6777 8211

Middle East and Africa

Dubai, United Arab Emirates
T +971 4 811 8100

D102683X012 © 1999, 2020 Emerson Process Management Regulator Technologies, Inc. All rights reserved. 09/20.

The Emerson logo is a trademark and service mark of Emerson Electric Co. All other marks are the property of their prospective owners. Fisher™ is a mark owned by Fisher Controls International LLC, a business of Emerson Automation Solutions.

The contents of this publication are presented for informational purposes only, and while every effort has been made to ensure their accuracy, they are not to be construed as warranties or guarantees, express or implied, regarding the products or services described herein or their use or applicability. All sales are governed by our terms and conditions, which are available upon request. We reserve the right to modify or improve the designs or specifications of such products at any time without notice.

Emerson Process Management Regulator Technologies, Inc. does not assume responsibility for the selection, use or maintenance of any product. Responsibility for proper selection, use and maintenance of any Emerson Process Management Regulator Technologies, Inc. product remains solely with the purchaser.



The distinctive swirl pattern cast into every actuator casing uniquely identifies the regulator as part of the Fisher™ brand Commercial Service Regulator family and assures you of the highest-quality engineering, performance, and support traditionally associated with Fisher™ and Tartarini™ regulators. Visit www.fishercommercialservice.com to access interactive applications.

