

neunovità
nouveau new

LGW...A2

• RoHS 2002/95/EG

Differential pressure switch for air, flue and exhaust gases

DUNGS®
Combustion Controls

LGW...A2, LGW...A2P
5.13



Technical description

The differential pressure switches LGW...A2, LGW...A2P are adjustable differential pressure switches as per EN 1854 for automatic burner controls. Suitable for switching a circuit on, off or over on changes in actual pressure value relative to the set reference value. The reference value (switching point) is adjusted on a setting wheel provided with a scale. On LGW...A2P: test button integrated in lower part as standard.

Application

Differential pressure monitoring in firing, ventilation and air-conditioning systems. Suitable for air, flue and exhaust gases and other non-aggressive gases as differential pressure switches; not suitable for industrial combustion gases.

Approvals

EC type test approval as per EC Gas Appliance Directive:

LGW A2, A2P CE-0085 AQ 0673

EC type test approval as per EC Pressure Equipment Directive:

LGW A2, A2P CE0036

TÜV (German Technical Inspectorate) test as pressure switch; special construction type as per TRD 604 and VdTÜV leaflet, Edition 100/1, as well as Class "S" as per EN 1854.

Special designs for the North American market with UL, FM and CSA registrations.

Approvals in other important gas-consuming countries.

Functional description

Differential pressure switch in pressure and vacuum range. The differential pressure acts via the diaphragm against the force of the setting spring on the microswitch. The pressure switch operates without auxiliary power.

LGW...A2 differential pressure switch

The control unit responds to differential pressure. If the set reference value (mbar) is exceeded or undershot, the circuit is switched on, off or over.

LGW...A2P test button

The LGW...A2P differential pressure switch is equipped with a test button. The test button permits a service-friendly check of the safety function. If the test key is pressed while the pressure exists, the connection to the pressure connection **G 1/4** is interrupted and the pressure under the diaphragm is released. The microswitch of the pressure switch changes the contact position from NO to NC. If the test button is released, the pressure below the diaphragm is built up again and the microswitch changes to its original position.

LGW...A2, LGW...A2P switching function

As pressure rises:
 1 NC opens, 2 NO closes
As pressure falls:
 1 NC closes, 2 NO opens

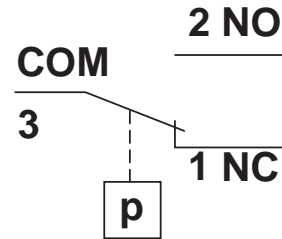

Definition of switching difference Δp

The switching difference Δp is the pressure difference between the upper and lower switching pressures.

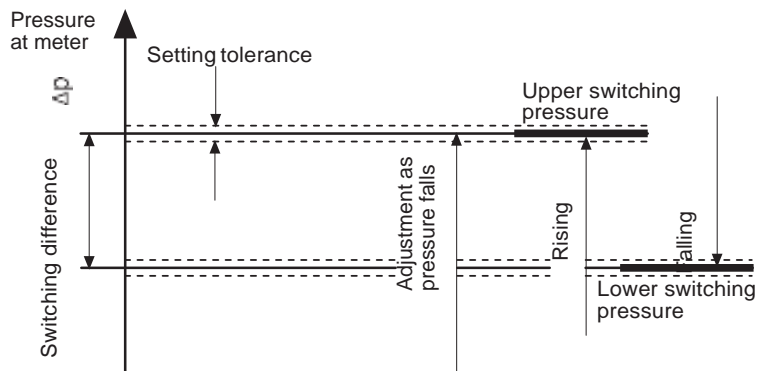

Dimensions [mm] LGW...A2

LGW...A2P

- A 2.5 dia for equipment plug as per DIN EN 175 301-803
- B Oblong slot: 0.8 and cross-head as per DIN 7962-Z 2
- 1 Pressure connection (+)
- 2 Pressure connection (-)
- 3 Only LGW... A2 optional pressure connection (+)
- 4 Test button p (+)

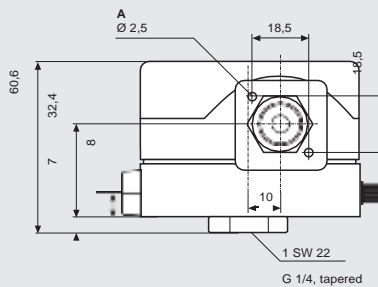

Pressure connection (+) $\varnothing 4.6$ can only be used as test nipple. Pressure connection (-) only possible using G 1/4.

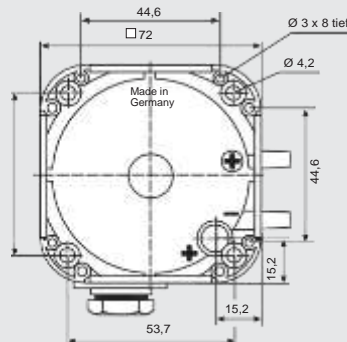
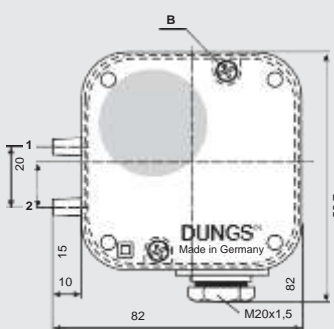
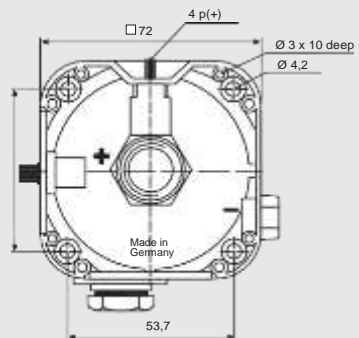
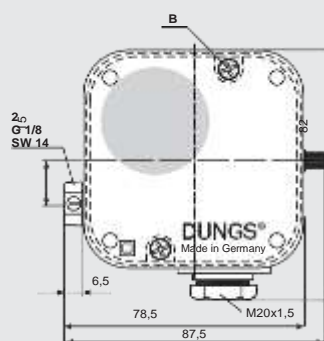
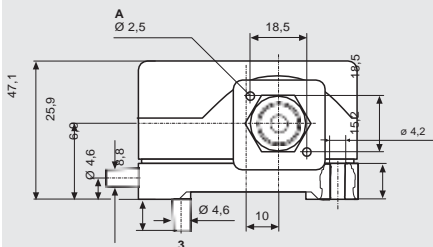

Specifications

Max. operating pressure	LGW 3 A2 - LGW 150 A2 LGW 3 A2P - LGW 150 A2P	500 mbar (50 kPa) 500 mbar (50 kPa)
Ranges	0.4 - 3 mbar 1 - 10mbar 2.5 - 50 mbar 30 - 150mbar	
Pressure connection	LGW A2: 4.6 mm dia. hosegland LGW A2P: G 1/4 tapered female thread for higher pressure on centre of housing underside, including test button and on the side 4.6 dia. test point; G 1/8 female thread for lower pressure	
Temperature range	Ambient temperature -15 °C to +70 °C Medium temperature -15 °C to +70 °C Storage temperature -30 °C to +85 °C	
Materials	Housing: polycarbonate Switch: polycarbonate Diaphragms: NBR Switching contact: standard: Ag optional: Ag gold-plated (AU); suitable for DDC applications: 24 V DC; 0.01 A	
Switching voltage	Ag contact: AC eff. min. 24 V max. 250V DC min. 24 V max. 48 V Au contact: DC min. 5 V max. 24 V	
Nominal current	Ag contact: AC eff. 10 A Au contact: DC 20 mA	
Switching current	Ag contact: AC eff. max. 6 A at cos φ 1 AC eff. max. 3 A at cos φ 0.6 AC eff. min. 20 mA DC min. 20 mA DC max. 1 A Au contact: DC min. 5 mA max. 20 mA	
Electrical connection	Standard: At screw terminals via M20x1.5 cable entry Special design: Plug connection for line sockets as per DIN EN 175 301-803, 3-pin	
Degree of protection	IP 54 as per IEC 529 (EN 60529), protection insulated	
Adjustment	Optionally adjustment for rising or falling pressure possible on site	
Setting tolerance	±15% switching point deviation referred to reference value, adjusted as pressure rises, vertical diaphragm position	

Installation position

Standard installation position with **vertically** upright diaphragm. When installed **horizontally**, the pressure switch switches at a pressure higher by approx. 0.5 mbar

When installed **horizontally overhead**, the pressure switch switches at a pressure lower by approx. 0.5 mbar

When installed in an **intermediate installation position**, the pressure switch switches at pressure deviating from the set reference value by max. ± 0.5 mbar.

**Differential pressure switch for air,
 flue and exhaust gases**

LGW...A2, LGW...A2P



Technical data

1mbar = 100 Pa = 0.1 kPa ≈ 10 mm WS

1 Pa = 0.01 mbar ≈ 0.1 mm WS

Type	Version [Ag-M-V9]	Order No.	Setting range [mbar]	Switching difference Δp [mbar]
LGW A2 Differential pressure switch	LGW 3 A2	107 409	0.4 - 3	≤ 0.3
	LGW 10 A2	107 417	1 - 10	≤ 0.5
	LGW 50 A2	107 425	2.5 - 50	≤ 1
	LGW 150 A2	107 433	30 - 150	≤ 3
	LGW 3 A2P	120 204	0.4 - 3	≤ 0.3
	LGW 10 A2P	120 212	1 - 10	≤ 0.5
	LGW 50 A2P	221 207	2.5 - 50	≤ 1
	LGW 150 A2P	120 238	30 - 150	≤ 3

**Accessories for
 LGW...A2, LGW...A2P pressure switches**

Kit: G3 equipment plug, 3-pin without ground	231 770
Line socket, 3-pin + E, grey GDMW	210 318
KlimaSet accessories KS A2	214 828
G 1/8 screw-in gland	230 278
G 1/4 screw-in gland	230 279
Additional test button, complete PT 4	224 940
Attachment plate	230 301
Mounting kit glow lamp 230 V yellow	231 773
Mounting kit glow lamp 120 V yellow	231 772
Mounting kit display-LED 24 V yellow	231 774
Mounting kit glow lamp 230 V green	248 239
Mounting kit display-LED 24 V green	248 240

We reserve the right to make any changes in the interest of technical progress.