



บริษัท เอดีดี เฟอร์เนส จำกัด

ADD FURNACE CO.,LTD.

44 ซอยบรมราชชนนี 70 ถนนบรมราชชนนี แขวงศาลาธรรมสพน์ เขตทวีวัฒนา กรุงเทพฯ 10170

โทร: 02-888-3472 โทร: ออกแบบ:08-08-170-170 แฟกซ์: 02-888-3258

https://www.add-furnace.com E-mail: sales@add-furnace.com

Version 1.6(2014.09.10)



CONOTEC

Registration of Design 0316273  
Digital Temperature  
Controller

CONOTEC CO., LTD.

www.conotec.co.kr

## Operating Manual



FOX-2C1



FOX-2C2

### 1 Caution

#### ※ Safety and Hazard Instructions

##### △ Safety

Pls use this item after installing the duplex safety device in which is applied at dangerous factors such as serious human injury or serious damages of property & important machine because this item is not designed as safety device

##### △ Safety Instruction and Hazard Warnings

- Please read the operating manual throughly before putting the device into operation
- We will not assume any responsibility for damage to assets or persons caused by improper handling or failure to observe the safety instructions or hazard warnings
- For safety and licensing reasons, unauthorized conversion and/or modification of the device is not permitted.
- Do not exceed the maximum permissible current – in case of higher loads, use a contactor of adequate power. Make sure that the supplied voltage matches the values specified for the instrument.
- The device must be adequately protected from water and dust as per the application and must be accessible via the use of appropriate tools
- The device must not be exposed to extreme temperature, sunlight, strong vibrations or high levels of humidity.
- Operation or installation is not permitted under unfavorable ambient conditions such as wetness or excessive induction loads or solenoid and dust, combustible gases, vapors or solvents, especially high-frequency noise
- Avoid operation or installation close to high-frequency fields such as welding devices, sewing machines, wireless transmitter, radio systems, SCR controller, etc
- Do not install the sensor cable nearby signal cable, power cable, load cable.
- Please use the shield cable when the sensor cable's lengthen, however do not make it too much longer
- Please use the sensor cable without any cutting or flaw, blemish.

- The device is not a toy and should be kept away from children
- Installation work must only be carried out by suitably qualified personnel who are familiar with the hazards involved and with the relevant regulations.
- You shouldn't tinker with anything or the product may not be opened or disassembled unless you know what you're doing.
- Please ask us about this questioning

##### ⚠ Danger

- Attention! Never work on electrical connections when the machine is switched on

### 2 Operation Manual

Model	Sensor	Temp.range	Size(mm)	Output	Function
2C1	K(CA)	-50℃~1200℃	77(W)x35(H)	100~240VAC 50/60Hz	Temp.
2C2	K(CA)	-50℃~1200℃	77(W)x35(H)		
2C1-D	K(CA)	-50℃~1200℃	77(W)x35(H)	AC:17~28V DC:12~35V	Temp.
2C2-D	K(CA)	-50℃~1200℃	77(W)x35(H)	AC:17~28V DC:12~35V	Temp.(1R) Alarm(2R)

### 3 Part name

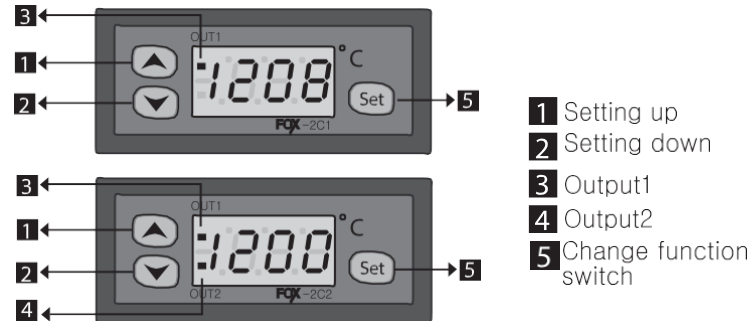

### Setting temperature & programs

- setting temperature

The present temperature shall be displayed after turning on of the power supply.

If **Set** key is pressed softly, **SET** letter will be showed and then, if **Set** key is pressed again, setting temperature will be flicked.

Press **▲** **▼** key to change the set values

If **Set** key is pressed again, **o-L** letter shall be showed and the setting temperature value shall be saved and the present temperature shall be displayed.

- Setting programs

If **Set** key is pressed for more than 5seconds, the program mode will be proceeded as following sequences HSP->LSP->TYP->DLT->DIF->COR->...

The setting value of each mode should changed by pressing **▲** **▼** key and then press **Set** key to move to next mode

- ※ The set or programming mode is terminated, if you press the **Set** key for more than 2 second, parameters(set values) are saved after showing **o-L** letter or return to the present temperature automatically after 10seconds



Relay junction

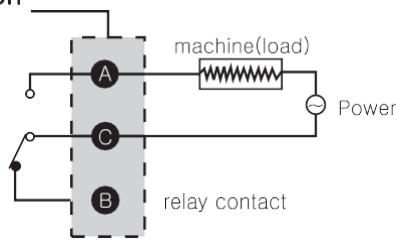

\*Relay contact capacity – less than 250VAC 2A

4 Connection

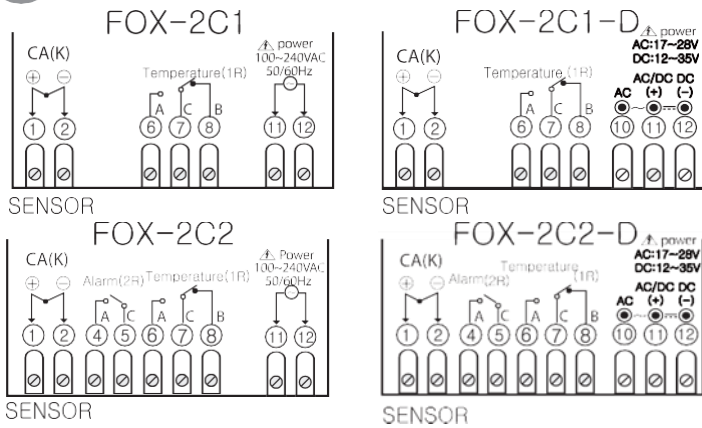

5 Terminology

• cold junction compensating circuit

If the thermocouple sensor would be connected to the input terminal of the controller, it might be some errors by bring thermally generated emf in proportion to the ambient temperature in the the contact point between the input terminal's metal and the thermocouple sensor wire. To prevent, it is embedded in cold junction compensating circuit.

• compensating wire

- It is usually used at lengthening of the cable between thermocouple sensor and the controller
  - If a general cable should be used, the contact point between thermocouple wire and general wire might be some errors by becoming another thermocouple sensor . To prevent it, it should be lengthen of the same wire as thermocouple's wire. The compensating wire usually consist of red wire for + polarity and blue(or white) one for - polarity
- When using of the compensating wire, pay attention in order not to be reversed for the polarity each other

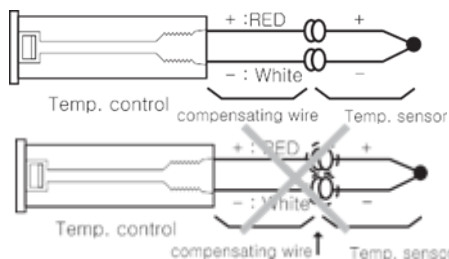

6 Dimension

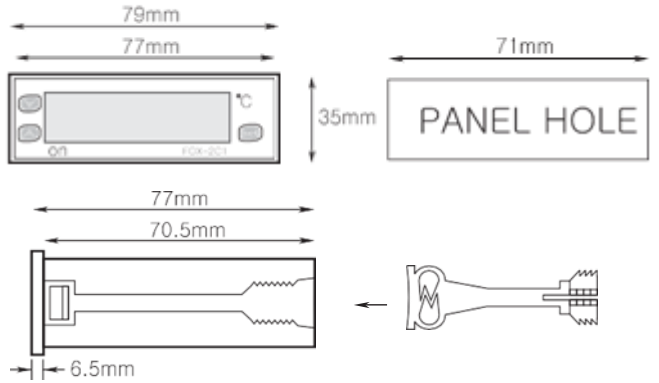

7 Sequence

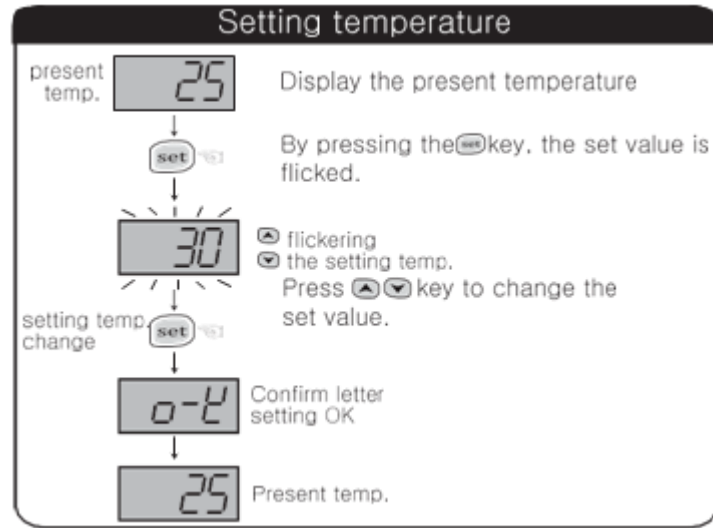



บริษัท เอดีดี เฟอร์เนส จำกัด

ADD FURNACE CO.,LTD.

44 ซอยบรมราชชนนี 70 ถนนบรมราชชนนี แขวงศาลาธรรมสพน์ เขตทวีวัฒนา กรุงเทพฯ 10170

โทร: 02-888-3472 โทร: ออกแบบ:08-08-170-170 แฟกซ์: 02-888-3258

https://www.add-furnace.com E-mail: sales@add-furnace.com

### Setting for programs(2C1)

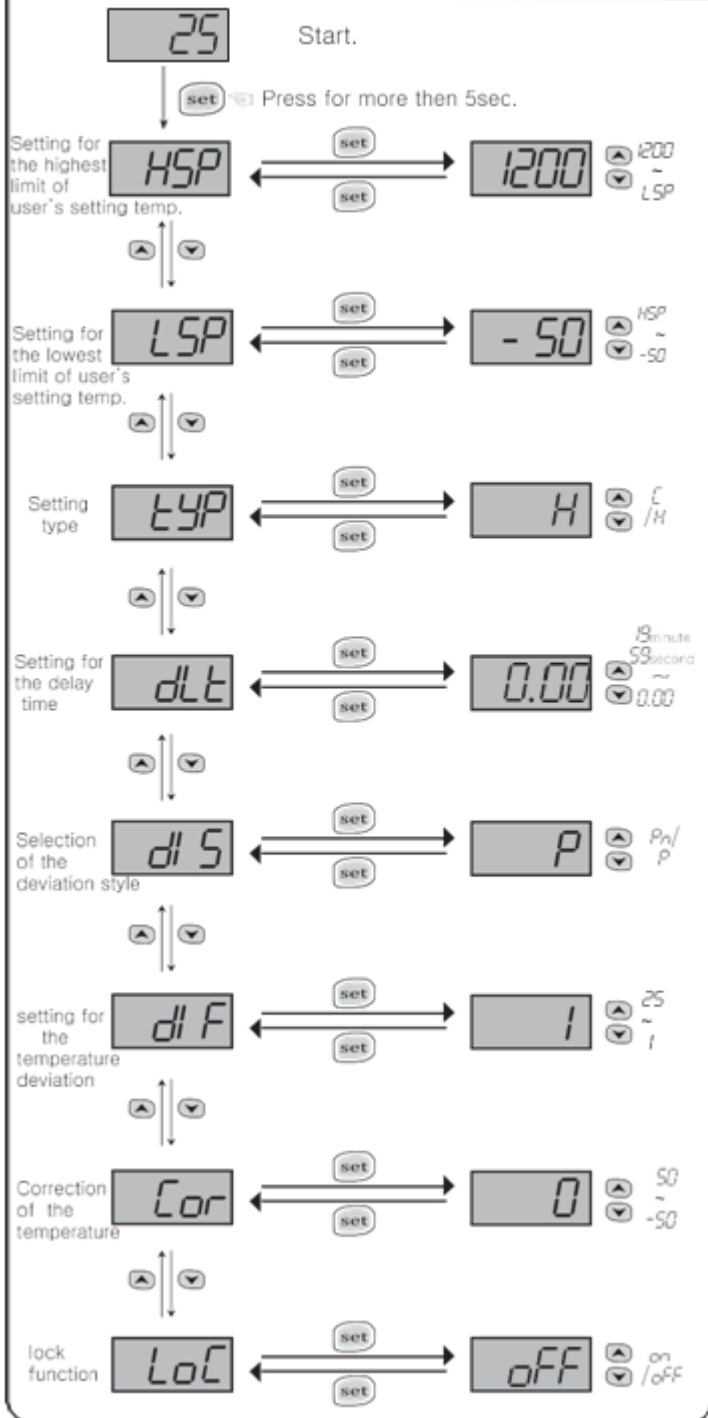

### Setting for programs(2C2)

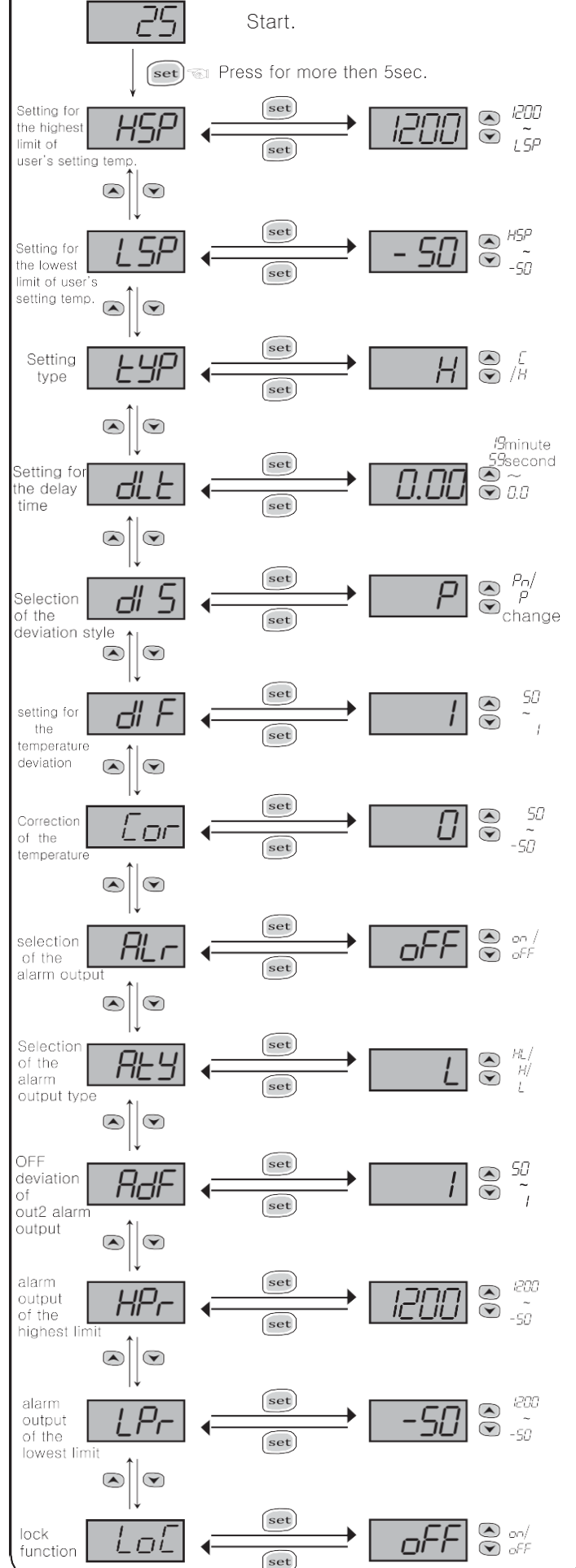



8 Detailed manual

**HSP** : Setting function of the highest limit of temperature range (Maximum set point allowed to the end user)  
 -Impossible to set up the set value more than **HSP** set value  
 ex) **HSP** = 25°C setting → impossible to raise the set value more than 25°C

**LSP** : Setting function of the lowest limit of temperature range (Minimum set point allowed to the end user)  
 -Impossible to set up the set value less than **LSP** set value  
 ex) **LSP** = 10°C setting → impossible to lower the set value less than 10°C

**LTP** : Selection of the Cooling(**CoL**) & Heating(**HEt**)

**dLT** : Delay time of the output  
 It is widely used as the followings  
 -in case of operation machinery when re-input of the power supply or momentary stoppage of power supply

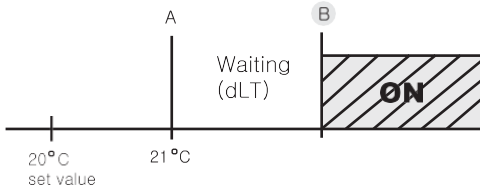

ex) If the set value is 1 :  
 from **A** until **B** time → the relay is ON in the **B** point after as delay as the **dLT** setting time(1min.) (flickering the output lamp during the **dLT** time)

**dI S** : Selection of deviation style

**P** Output : +deviation (be off at setting point)

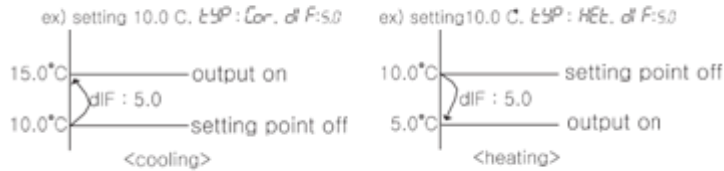

**Pn** Output : ±deviation (based on the setting point)

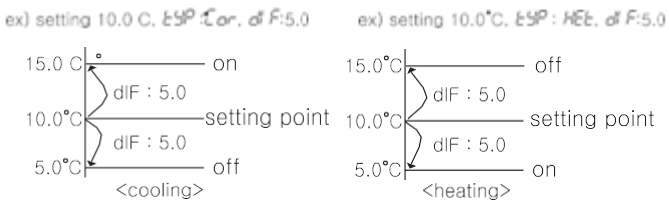

**dI F** : Setting for temperature deviation  
 - In the ON/OFF control, it need at regular interval between ON and OFF  
 - By operating the ON/OFF control frequently, the relay or its output contact can be damaged quickly and it also occurs the hunting(oscillating, chattering) by virtue of external noise. You can make use of the temperature deviation in order to protect its relay or contact and so on

ex) The method of the temp.deviation when ON/OFF control

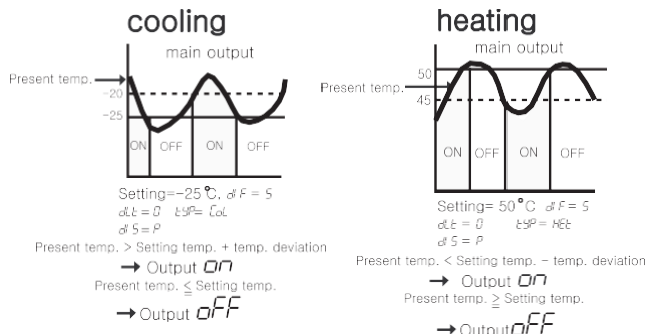

**Cor** : Correction of the present temperature.  
 It is used for the correction of a discrepancy between the display temperature and an actual temperature.

ex) actual temp : 10°C → **Cor** : 0.0 → -2 correction → 10°C display  
 display : 12°C

**ALr** : **on**: alarm on  
**off** : alarm off

**ALy** : selection of the alarm

**HL** : alarm of the highest & lowest limit  
 Output on – more than **HPR** setting value or less than **LPR** setting value

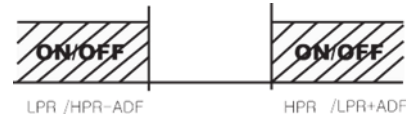

**H** : alarm of the highest  
 Output on – more than **HPR** setting value

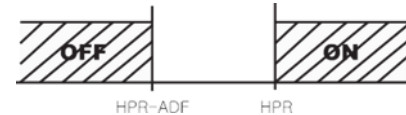

**L** : alarm of the lowest limit  
 Output on less than **LPR** setting value

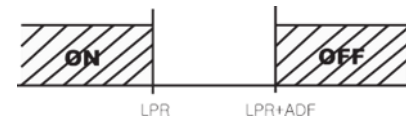

**AdF** : OFF deviation of Out2 alarm output

**HPr** : setting for highest alarm

**LPr** : setting for lowest alarm

**LoC** : **on**: lock function on

**off** : lock function off

■ ex) application

ex) Heater → turn off at 30°C ,turn on at 25°C  
 How to operate(setting for the temperature&programs)?

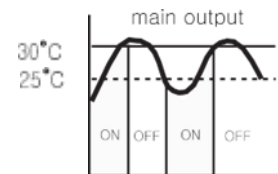

<Setting temp.> (see the setting temperaturure)  
 setting : 30°C  
 <Setting program> (see the setting for program)  
**LTP** : **HEt**  
**dI S** : **P**(deviation → one side, set point → off)  
**dI F** : 5 (on/off interval → 5 )

ex) Cooler → turn off at 0°C ,turn on at 2°C  
 How to operate(setting for the temperature&programs)?

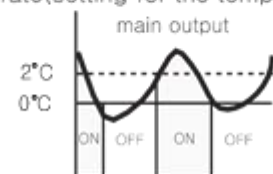





<Setting temp.> (see the setting temperaturure)  
setting : 0°C  
<Setting program> (see the setting for program)  
tYP : CoL  
dI S : P(deviation→one side, set point →off)  
dI F : 2 (on/off interval →2 )

9 Temp.range&set value when deliver

Function	set value when deliver	Function	set value when deliver
HSP	1200	ALr	oFF
LSP	-50	ALY	L
tYP	H	AdF	I
dLt	0.00	HPr	1200
dI S	P	LPr	-50
dI F	I	LoC	oFF
Cor	0		

10 Error message

- Er I Memory error. Turn the power off and turn it on again  
If the error message persists, please request us A/S by return
- o-E Sensor error. The sensor is interrupted.Check the cable.
- S-E Sensor error. The sensor is short-circuited. Check the cable